

# LISTA DE APLICACIONES - BUYERS GUIDE

## 151430



8 424073 083951

Qty: 660

Weight: 8.532

O.E.M.	MAKE
144 0504	DAF
2611-12999747VT	MACK
5001 855 902	RENAULT TRUCKS
7485 137 789	RENAULT TRUCKS

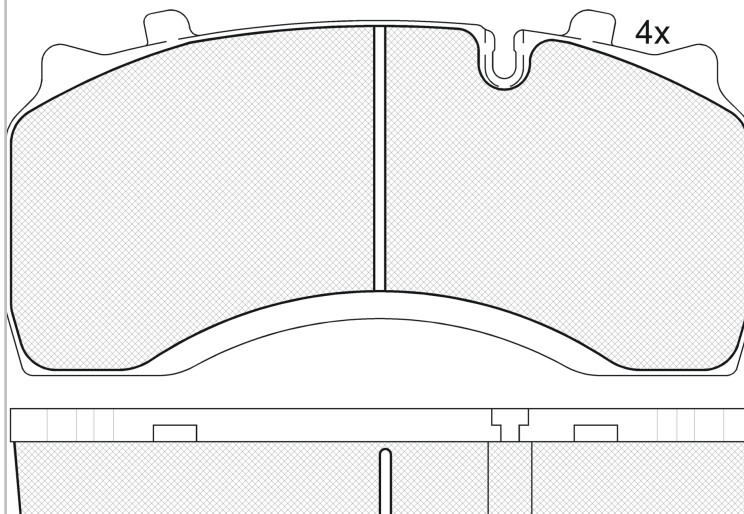

## 151430

E 9 90R-01178/749



Perrot-Wabco PAN 19-2

204.2x99.7x29.85

WVA	FMSI
29119	D1517-8726
29141	
29142	
MAKE	
DAF	
RENAULT TRUCKS	



Trac.	CC	Kw	CV
-------	----	----	----



Front / Rear

### DAF

#### LF 55 01.01-

#### Platform/Chassis

Model	Fuel	CC	Kw	CV	Trac.	01.01-	Front	Rear
FA 55.170 (BE 123 C)	Diesel	3920	123	167	01.01-	■	■	
FA 55.180 (CE 136 C)	Diesel	5880	136	185	01.01-	■	■	
FA 55.180 (CE 136 C)	Diesel	5880	136	185	01.01-	■	■	
FA 55.220 (CE 162 C)	Diesel	5880	162	220	01.01-	■	■	
FA 55.220 (CE 162 C)	Diesel	5880	162	220	01.01-	■	■	
FA 55.250 (CE 184 C)	Diesel	5880	184	250	01.01-	■	■	

#### LF 55 01.01-

#### Truck Tractor

FT 55.180 (CE 136 C)	Diesel	5880	136	185	01.01-	■	■
FT 55.220 (CE 162 C)	Diesel	5880	162	220	01.01-	■	■
FT 55.250 (CE 184 C)	Diesel	5880	184	250	01.01-	■	■

### RENAULT TRUCKS

#### 05.06-

#### Platform/Chassis

220.12 (DXI 5)	Diesel	4764	158	220	05.06-	■	■
220.14 (DXI 5)	Diesel	4764	158	220	05.06-	■	■

#### Midlum 01.00-

#### Dump Truck

210.12/C (MIDR 06.02.26 W/4)	Diesel	6177	154	209	01.00-	■	■
210.13/C (MIDR 06.02.26 W/4)	Diesel	6177	154	209	01.00-	■	■
210.15/C (MIDR 06.02.26 W/4)	Diesel	6177	154	209	01.00-	■	■
250.12/C (MIDR 06.02.26 Y/41)	Diesel	6177	184	250	01.00-	■	■
250.13/C (MIDR 06.02.26 Y/41)	Diesel	6177	184	250	01.00-	■	■
250.15/C (MIDR 06.02.26 Y/41)	Diesel	6177	184	250	01.00-	■	■

# LISTA DE APLICACIONES - BUYERS GUIDE

Midlum 01.00-					Municipal Vehicle				
220.15 (DCI 6W)		Diesel		6177	158	215	10.01-	■	■
Midlum 01.00-					Platform/Chassis				
180.14		Diesel		4118	130	177	07.01-04.06	■	■
180.16		Diesel		4118	130	177	07.01-04.06	■	■
210.12/C, 220.12/C (DCI 6W)		Diesel		6177	154	209	01.00-	■	■
210.12/C, 220.12/C (MIDR 06.02.26 W/4)		Diesel		6177	154	209	01.00-	■	■
210.13/C, 220.13/C, 220.13/D (DCI 6W)		Diesel		6177	154	209	01.00-	■	■
210.13/C, 220.13/C, 220.13/D (MIDR 06.02.26 W/4)		Diesel		6177	154	209	01.00-	■	■
210.14/C, 220.14/C, 220.14/D (DCI 6W)		Diesel		6177	154	209	01.00-	■	■
210.14/C, 220.14/C, 220.14/D (MIDR 06.02.26 W/4)		Diesel		6177	154	209	01.00-	■	■
210.15/C (MIDR 06.02.26 W/4)		Diesel		6177	154	209	01.00-	■	■
210.16/C, 220.16/C, 22.16/D (DCI 6W)		Diesel		6177	154	209	01.00-	■	■
210.16/C, 220.16/C, 22.16/D (MIDR 06.02.26 W/4)		Diesel		6177	154	209	01.00-	■	■
220.12 (DCI 6W)		Diesel		6177	158	215	10.01-	■	■
220.14 (DCI 6W)		Diesel		6177	158	215	10.01-	■	■
220.16 (DCI 6W)		Diesel		6177	158	215	10.01-	■	■
220.18/D (DCI 6W)		Diesel		6177	158	215	10.01-	■	■
220.13		Diesel		6177	160	218	07.01-04.06	■	■
220.15		Diesel		6177	160	218	07.01-12.06	■	■
220.18		Diesel		6177	160	218	07.01-04.06	■	■
250.12/C (MIDR 06.02.26 Y/41)		Diesel		6177	184	250	01.00-	■	■
250.13/C (MIDR 06.02.26 Y/41)		Diesel		6177	184	250	01.00-	■	■
250.14/C (MIDR 06.02.26 Y/41)		Diesel		6177	184	250	01.00-	■	■
250.15/C (MIDR 06.02.26 Y/41)		Diesel		6177	184	250	01.00-	■	■
250.16/C (MIDR 06.02.26 Y/41)		Diesel		6177	184	250	01.00-	■	■
270.12/C (DCI 6A)		Diesel		6177	195	265	10.01-	■	■
270.13/C, 270.13/D (DCI 6A)		Diesel		6177	195	265	10.01-	■	■
270.14/C, 270.14/D (DCI 6A)		Diesel		6177	195	265	10.01-	■	■
270.16/C, 270.16/D (DCI 6A)		Diesel		6177	195	265	10.01-	■	■
270.18/D (DCI 6A)		Diesel		6177	195	265	10.01-	■	■
270.15		Diesel		6177	198	269	07.01-04.06	■	■
Midlum 01.00-					Truck Tractor				
250.16/CT (MIDR 06.02.26 Y/41)		Diesel		6177	184	250	01.00-	■	■
270.16/B		Diesel		6177	195	265	10.01-	■	■
270.16/C (DCI 6A)		Diesel		6177	195	265	10.01-	■	■
270.15		Diesel		6177	198	269	07.01-04.06	■	■