

LISTA DE APLICACIONES - BUYERS GUIDE

180586



8 424073 009234

Qty: 300

Weight: 955

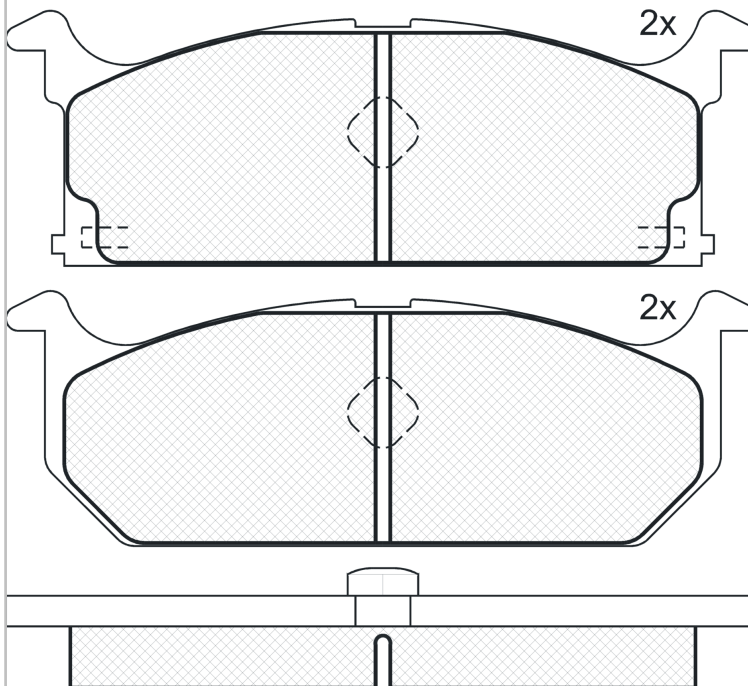

180586



Akebono

123.1x41.7x15

WVA

21252

21253

FMSI

D296-7197

MAKE

SUZUKI



Trac.	CC	Kw	CV
-------	----	----	----



Front / Rear

SUZUKI

ALTO (OS) 03.79-08.84						Hatchback (City car-A Segment)		
0.8 (SS80) (F8B)		Gasolina	FWD	796	29	39	06.82-08.84	■
0.8		Gasolina	FWD	797	29	39	10.83-08.84	■
SJ413 / SIERRA / SAMURAI (OS) 09.84-03.91						Closed Off-Road Vehicle (Mini SUV-J Segment)		
1.3 (SJ413) (G13A)		Gasolina	4WD	1324	47	64	09.84-08.90	■
SWIFT / CULTUS / SA 310 (AA) 10.83-12.89						Hatchback (Supermini car-B Segment)		
1.0 (SA310, AA41/43) (G10)	-12/88	Gasolina	FWD	993	37	50	10.83-03.89	■
1.0 (SA310, AA41/43) (G10A)	-12/88	Gasolina	FWD	993	37	50	10.83-03.89	■
1.0 Turbo (SA310) (G10T)	-12/88	Gasolina	FWD	993	52	71	02.85-12.89	■
1.0	01/84-	Gasolina	FWD	995	33	45	10.83-	■
1.3 (SA413, AA53) (G13A)	-12/88	Gasolina	FWD	1324	47	64	08.86-03.89	■
1.3 (SA413, AA51) (G13A)	-12/88	Gasolina	FWD	1324	50	68	10.84-03.89	■
1.3 (SA413, AA51/53) (G13A)	-12/88	Gasolina	FWD	1324	54	73	10.84-03.89	■