

LISTA DE APLICACIONES - BUYERS GUIDE

180605



Qty: 300

Weight: 1.090

O.E.M.	MAKE
04465-12430	TOYOTA
04465-14050	TOYOTA
04491-12093	TOYOTA
04491-12130	DAIHATSU
04491-12200	TOYOTA

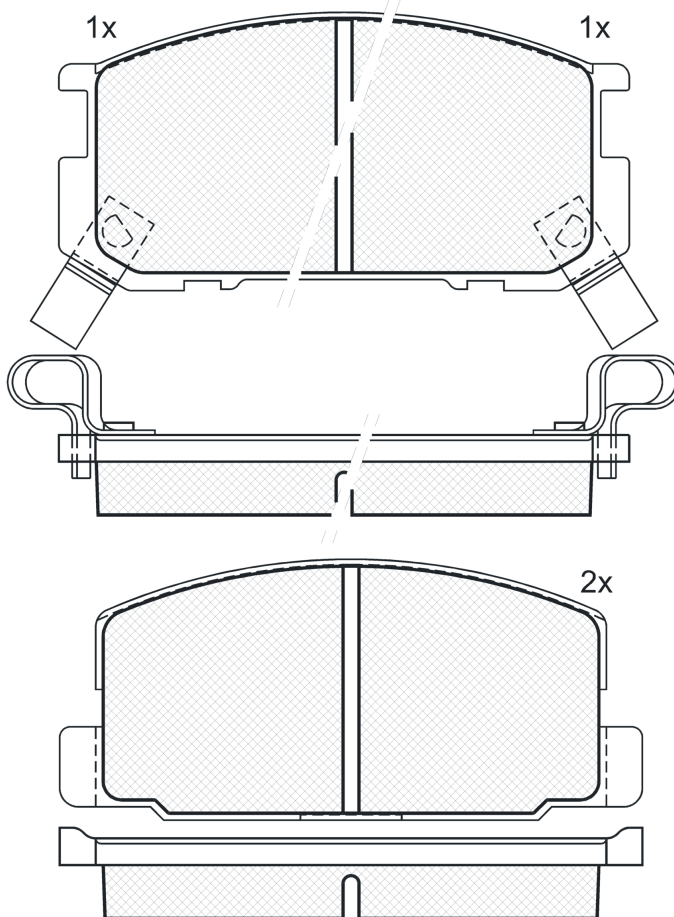

180605



Akebono

106.78x52.17x15

108.94x48.87x15

WVA	FMSI
20856	D282-7184
20867	
20875	

MAKE
DAIHATSU
TOYOTA



Trac.	CC	Kw	CV		
Front / Rear					

DAIHATSU

CHARMANT II (A) 10.81-07.87						Saloon (Compact car-C Segment)			
1.6 (A60) (4A)		Gasolina	RWD	1587		61	83	08.83-07.87	■

TOYOTA

CARINA II-III (_A6_) 03.81-09.83						Estate (Compact car-C Segment)			
1.8 (TA62_, TA62R) (3T-C)		Gasolina	RWD	1770		57	78	08.82-12.82	■

CARINA II-III (TA4_, TA6_) 05.73-09.83						Saloon (Compact car-C Segment)			
1.8 (TA62_, TA62) (3T)	01/81-	Gasolina	RWD	1770		57	78	01.78-05.83	■
1.8 (TA62_, TA62) (3T-C)	01/81-	Gasolina	RWD	1770		57	78	01.78-05.83	■
1.8 (TA63) (3T)		Gasolina	RWD	1770		62	84	08.81-09.83	■
1.8 (TA63) (3T-C)		Gasolina	RWD	1770		62	84	08.81-09.83	■

CELICA II (_A4_) 08.77-07.81						Hatchback (Sports car-S Segment)			
1.6 ST (TA40_, TA40R) (2TB)		Gasolina	RWD	1588		63	86	08.77-07.81	■
1.6 ST (TA40_, TA40R) (2T)		Gasolina	RWD	1588		66	90	02.79-07.81	■

CELICA III (_A6_) 08.81-12.85						Coupe (Sports car-S Segment)			
1.6 (AA63_, AA63R) (4A-GE)		Gasolina	RWD	1587		91	124	12.83-12.85	■

COROLLA V (_E8_) 05.82-05.89						Hatchback (Supermini car-B Segment)			
1.6		Gasolina	FWD	1587		85	116	05.85-04.87	■

COROLLA V / COROLLA SPRINTER (AE86) 05.83-07.87						Coupe (Supermini car-B Segment)			
1.6 SR (AE86) (4A-C)		Gasolina	RWD	1587		57	78	05.83-04.87	■
1.6 SR		Gasolina	FWD	1587		58	79	08.83-04.85	■
1.6 16V (AE86_, AE86) (4A-GEC)		Gasolina	RWD	1587		85	115	12.85-04.87	■

LISTA DE APLICACIONES - BUYERS GUIDE

1.6 GT 16V (AE86) (4A-GE)		Gasolina	RWD	1587	91	124	08.83-07.87	■	
1.6 GTi Twin Cam (AE86_, AE86)		Gasolina	RWD	1587	96	131	06.83-07.87	■	
COROLLA V Compact (E8B) 08.84-05.88							Hatchback (Supermini car-B Segment)		
1.6		Gasolina	FWD	1587	85	116	05.85-04.87	■	
1.6 GT 16V (AE82_) (4A-GEL)		Gasolina	FWD	1587	89	121	08.85-08.87	■	
CORONA VI (_T1_) 09.78-12.83							Saloon (Large family car-D Segment)		
1.6 SD, GL	01/82-	Gasolina	FWD	1595	55	75	09.78-	■	
1.8	01/82-	Gasolina	FWD	1795	55	75	09.78-	■	
2.0 DLX	01/84-	Gasolina	FWD	1995	65	88	09.78-	■	
2.4 Csi, Cxi	01/84-	Gasolina	FWD	2395	68	92	09.78-	■	
CORONA VII (_T14_) 08.83-08.88							Estate (Large family car-D Segment)		
2.0	01/84-	Gasolina	FWD	1995	65	88	08.83-	■	
CORONA VII (_T14_, _T15_, _T16_) 01.82-08.88							Saloon (Large family car-D Segment)		
2.0 D		Diesel	RWD	1974	54	73	01.84-08.88	■	
SPRINTER V 06.83-07.87							Coupe (Compact executive car-D Segment)		
1.6 GTi (AE86)		Gasolina	FWD	1587	91	124	10.84-07.87	■	
SPRINTER V 06.83-07.87							Hatchback (Compact executive car-D Segment)		
1.6 GTI		Gasolina	FWD	1587	91	124	10.84-07.87	■	
1.6 GTI		Gasolina	FWD	1587	96	131	06.83-07.87	■	