

# LISTA DE APLICACIONES - BUYERS GUIDE

## 181115-396



Qty: 300

Weight: 1.800

O.E.M.	MAKE
002 420 44 20	MERCEDES-BENZ
002 420 96 20	MERCEDES-BENZ
004 420 02 20	MERCEDES-BENZ
005 420 47 20	MERCEDES-BENZ

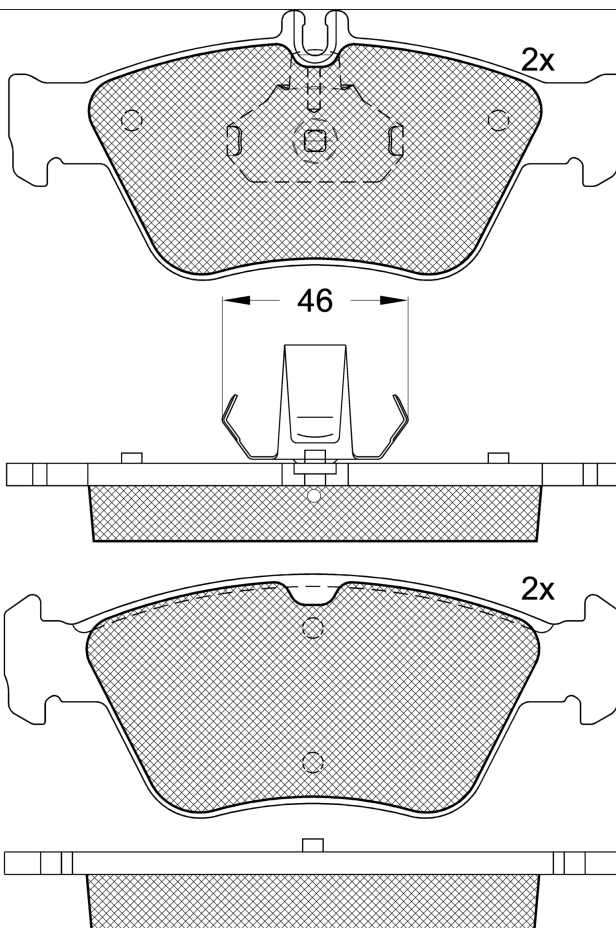

## 181115-396



E1 90R-01101/052

Ate - Teves

150.3x66.2x19.1

151.4x60.1x19.1

WVA	FMSI
21664	D710-7583
21665	
21795	
MAKE	
MERCEDES-BENZ	



Trac.	CC	Kw	CV
-------	----	----	----



Front / Rear

### MERCEDES-BENZ

#### C-Class (W202) 03.93-05.00

							Saloon (Executive car-E Segment)		
C 200 Kompressor (202.025) (M 111.944)		Gasolina	RWD	1998	132	180	10.95-05.00	■	
C 200 Kompressor (202.025) (M 111.944)		Gasolina	RWD	1998	141	192	11.96-05.00	■	
C 230 Kompressor (202.024) (M 111.975)		Gasolina	RWD	2295	142	193	10.95-05.00	■	
C 240 (202.026) (M 112.910)		Gasolina	RWD	2398	125	170	06.97-05.00	■	
C 280 (202.028) (M 104.941)	01/96-	Gasolina	RWD	2799	142	193	05.93-05.00	■	
C 280 (202.029) (M 112.920)		Gasolina	RWD	2799	145	197	06.97-05.00	■	
C 250 Turbo-D (202.128) (OM 605.960)		Diesel	RWD	2497	110	150	10.95-05.00	■	

#### C-Class T-Model (S202) 06.96-03.01

							Estate (Compact executive car-D Segment)		
C 200 T Kompressor (202.087) (M 111.956)		Gasolina	RWD	1998	120	163	09.00-03.01	■	
C 200 T Kompressor (202.087) (M 111.944)		Gasolina	RWD	1998	141	192	11.96-03.01	■	
C 230 T Kompressor (202.085) (M 111.975)		Gasolina	RWD	2295	142	193	06.97-09.00	■	
C 240 T (202.086) (M 112.910)		Gasolina	RWD	2398	125	170	06.97-09.00	■	
C 240 T (202.088) (M 112.915)		Gasolina	RWD	2597	125	170	09.00-03.01	■	
C 280 T (202.089) (M 112.920)		Gasolina	RWD	2799	145	197	06.97-03.01	■	
C 250 T Turbo-D (202.188) (OM 605.960)		Diesel	RWD	2497	110	150	06.96-03.01	■	

#### CLK-Class (A208) 03.98-03.02

							Convertible (Executive car-E Segment)		
CLK 200 (208.435) (M 111.941)	-12/00	Gasolina	RWD	1998	100	136	03.98-03.02	■	
CLK 200 (208.435) (M 111.945)	-12/00	Gasolina	RWD	1998	100	136	03.98-03.02	■	
CLK 200 Kompressor (208.445) (M 111.956)		Gasolina	RWD	1998	120	163	06.00-03.02	■	

#### CLK-Class (C208) 06.97-12.03

							Coupe (Executive car-E Segment)		
CLK 200 (208.335) (M 111.945)	-12/00	Gasolina	RWD	1998	100	136	06.97-06.02	■	

# LISTA DE APLICACIONES - BUYERS GUIDE

CLK 200 Kompressor (208.445) (M 111.956)	Gasolina	RWD	1998	120	163	06.00-06.02	■
CLK 200 Kompressor (208.445) (M 111.944)	Gasolina	RWD	1998	141	192	06.97-06.00	■
CLK 230 Kompressor (208.448) (M 111.973)	Gasolina	RWD	2295	142	193	06.97-06.00	■
CLK 230 Kompressor (208.448) (M 111.975)	Gasolina	RWD	2295	142	193	06.97-06.00	■
CLK 230 Kompressor (208.448) (M 111.982)	Gasolina	RWD	2295	145	197	06.00-06.02	■
CLK 320 (208.365) (M 112.940)	Gasolina	RWD	3199	160	218	06.97-06.02	■
<b>E-Class II (W210) 06.95-08.03</b>				<b>Saloon (Executive car-E Segment)</b>			
E 200 (210.035) (M 111.942)	Gasolina	RWD	1998	100	136	06.95-08.00	■
E 200 Kompressor (210.048) (M 111.957)	Gasolina	RWD	1998	120	163	08.00-03.02	■
E 230 (210.037) (M 111.970)	Gasolina	RWD	2295	110	150	06.95-06.97	■
E 240 (210.061) (M 112.911)	Gasolina	RWD	2398	125	170	06.97-08.00	■
E 240 (210.062) (M 112.914)	Gasolina	RWD	2597	125	170	08.00-03.02	■
E 200 D (210.003) (OM 604.917)	Diesel	RWD	1997	65	88	01.96-03.02	■
E 200 CDI (210.007) (OM 611.961)	Diesel	RWD	2148	85	116	07.99-03.02	■
E 220 CDI (210.006) (OM 611.961)	Diesel	RWD	2148	100	136	07.99-03.02	■
E 220 CDI (210.006) (OM 611.961)	Diesel	RWD	2148	105	143	07.99-03.02	■
E 200 CDI (210.007) (OM 611.961)	Diesel	RWD	2151	75	102	06.98-03.02	■
E 220 CDI (210.006) (OM 611.961)	Diesel	RWD	2151	92	125	06.98-07.99	■
E 220 D (210.004) (OM 604.912)	Diesel	RWD	2155	55	75	05.96-03.02	■
E 220 D (210.004) (OM 604.912)	Diesel	RWD	2155	70	95	06.95-07.99	■
E 250 D (210.010) (OM 605.912)	Diesel	RWD	2497	83	113	06.95-07.99	■
E 250 Turbo-D (210.015) (OM 605.962)	Diesel	RWD	2497	110	150	06.97-07.99	■
E 270 CDI (210.016) (OM 612.961)	Diesel	RWD	2685	125	170	07.99-03.02	■
E 290 Turbo-D (210.017) (OM 602.982)	Diesel	RWD	2874	95	129	03.96-07.99	■
E 300 D (210.020) (OM 606.912)	Diesel	RWD	2996	100	136	06.95-06.97	■
<b>E-Class II T-Model (S210) 06.96-03.03</b>				<b>Estate (Executive car-E Segment)</b>			
E 200 T (210.235) (M 111.942)	Gasolina	RWD	1998	100	136	06.96-08.00	■
E 200 T Kompressor (210.248) (M 111.957)	Gasolina	RWD	1998	120	163	08.00-03.03	■
E 230 T (210.237) (M 111.970)	Gasolina	RWD	2295	110	150	06.96-06.97	■
E 240 T (210.261) (M 112.911)	Gasolina	RWD	2398	125	170	06.97-03.03	■
E 240 T (210.262) (M 112.914)	Gasolina	RWD	2597	125	170	08.00-03.03	■
E 220 T CDI (210.206) (OM 611.961)	Diesel	RWD	2148	100	136	05.99-03.03	■
E 220 T CDI (210.206) (OM 611.961)	Diesel	RWD	2148	105	143	07.99-03.03	■
E 220 T CDI (210.206) (OM 611.961)	Diesel	RWD	2151	92	125	06.98-07.99	■
E 250 T D (210.210) (OM 605.912)	Diesel	RWD	2497	83	113	06.96-07.99	■
E 250 T Turbo-D (210.215) (OM 605.962)	Diesel	RWD	2497	110	150	06.97-07.99	■
E 270 T CDI (210.216) (OM 612.961)	Diesel	RWD	2685	125	170	07.99-03.03	■
E 290 T Turbo-D (210.217) (OM 602.982)	Diesel	RWD	2874	95	129	06.96-07.99	■
<b>SLK-Class (R170) 04.96-04.04</b>				<b>Convertible (Sports car-S Segment)</b>			
200 (170.435) (M 111.946)	Gasolina	RWD	1998	100	136	09.96-03.00	■
200 Kompressor (170.445) (M 111.958)	Gasolina	RWD	1998	120	163	03.00-04.04	■
200 Kompressor (170.445) (M 111.943)	Gasolina	RWD	1998	141	192	10.96-03.00	■
230 Kompressor (170.449) (M 111.973)	Gasolina	RWD	2295	142	193	09.96-03.00	■
230 Kompressor (170.449) (M 111.983)	Gasolina	RWD	2295	145	197	03.00-04.04	■