

LISTA DE APLICACIONES - BUYERS GUIDE

181159



Qty: 300

Weight: 1.992

O.E.M.	MAKE
000 420 50 20	MERCEDES-BENZ
002 420 45 20	MERCEDES-BENZ
002 420 50 20	MERCEDES-BENZ
004 420 03 20	MERCEDES-BENZ

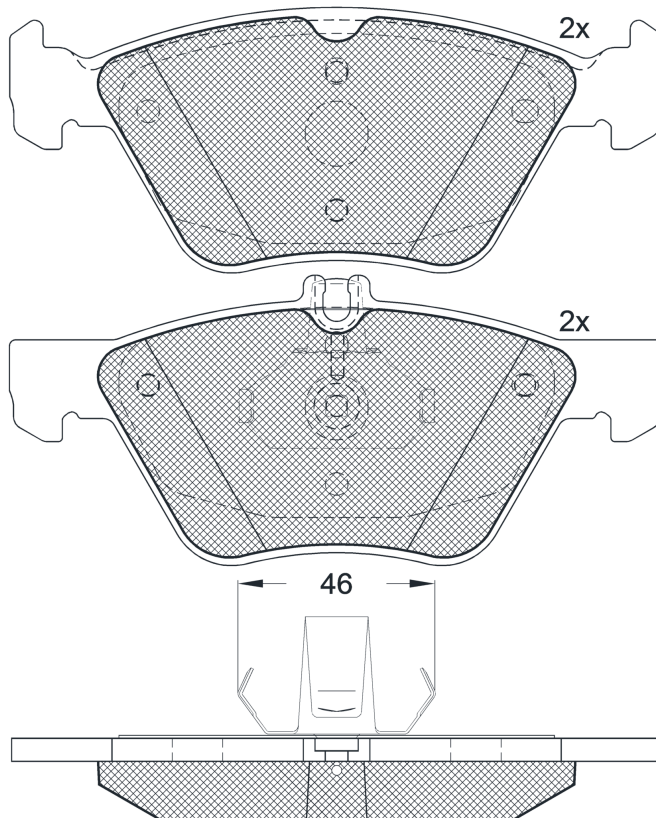

181159

E1 90R-01101/204



Ate - Teves

156.4x63.7x20.3
156.5x69.4x20.3

WVA	FMSI
21670	D740-7609
21671	
21940	
MAKE	
MERCEDES-BENZ	



Trac.	CC	Kw	CV		Front / Rear
-------	----	----	----	--	--------------

MERCEDES-BENZ

CLK-Class (A208) 03.98-03.02							Convertible (Executive car-E Segment)		
CLK 200 Kompressor (208.445) (M 111.956)		Gasolina	RWD	1998	120	163	06.00-03.02	■	
CLK 200 Kompressor (208.445) (M 111.944)		Gasolina	RWD	1998	141	192	03.98-06.00	■	
CLK 230 Kompressor (208.448) (M 111.973)		Gasolina	RWD	2295	142	193	03.98-06.00	■	
CLK 230 Kompressor (208.448) (M 111.975)		Gasolina	RWD	2295	142	193	03.98-06.00	■	
CLK 230 Kompressor (208.448) (M 111.982)		Gasolina	RWD	2295	145	197	06.00-03.02	■	
CLK 320 (208.465) (M 112.940)		Gasolina	RWD	3199	160	218	03.98-03.02	■	
CLK-Class (C208) 06.97-12.03							Coupe (Executive car-E Segment)		
CLK 320 (208.365) (M 112.940)		Gasolina	RWD	3199	160	218	06.97-06.02	■	
E-Class II (VF210) 06.96-03.03							Platform/Chassis (LCVs-N1 Segment)		
E 280 (210.663) (M 112.921)		Gasolina	RWD	2799	150	204	07.99-11.02	■	
E 220 CDi (210.606) (OM 611.961)		Diesel	RWD	2148	105	143	07.99-12.02	■	
E 250 d (210.610) (OM 605.912)		Diesel	RWD	2497	83	113	06.96-06.98	■	
E 270 CDI (210.616) (OM 612.961)		Diesel	RWD	2685	125	170	07.99-12.02	■	
E 290 TD (210.617) (OM 602.982)		Diesel	RWD	2874	95	129	07.96-07.99	■	
E-Class II (W210) 06.95-08.03							Saloon (Executive car-E Segment)		
E 200 Kompressor (210.048) (M 111.947)		Gasolina	RWD	1998	137	186	06.97-03.02	■	
E 240 (210.061) (M 112.911)		Gasolina	RWD	2398	125	170	06.97-08.00	■	
E 280 (210.053) (M 104.945)		Gasolina	RWD	2799	142	193	01.96-06.97	■	
E 280 (210.063) (M 112.921)	-12/97	Gasolina	RWD	2799	150	204	12.96-03.02	■	
E 280 4-matic (210.081) (M 112.921)	-12/97	Gasolina	4WD	2799	150	204	12.96-03.02	■	
E 320 (210.055) (M 104.995)		Gasolina	RWD	3199	162	220	06.95-06.97	■	

LISTA DE APLICACIONES - BUYERS GUIDE

E 320 (210.065) (M 112.941)	-12/98	Gasolina	RWD	3199	165	224	06.97-03.02	■
E 320 4-matic (210.082) (M 112.941)	-12/98	Gasolina	4WD	3199	165	224	06.97-03.02	■
E 36 AMG		Gasolina	RWD	3606	200	272	04.96-01.98	■
E 420 (210.072) (M 119.985)		Gasolina	RWD	4196	205	279	01.96-06.97	■
E 430 (210.070) (M 113.940)	-12/97	Gasolina	RWD	4266	205	279	06.97-03.02	■
E 270 CDI (210.016) (OM 612.961)		Diesel	RWD	2685	120	163	07.99-03.02	■
E 270 CDI (210.016) (OM 612.961)		Diesel	RWD	2685	125	170	07.99-03.02	■
E 300 Turbo-D (210.025) (OM 606.962)	-12/97	Diesel	RWD	2996	130	177	12.96-07.99	■
E 320 CDI (210.026) (OM 613.961)		Diesel	RWD	3222	145	197	07.99-03.02	■
E-Class II T-Model (S210) 06.96-03.03				Estate (Executive car-E Segment)				
E 200 T Kompressor (210.248) (M 111.947)		Gasolina	RWD	1998	137	186	06.97-03.03	■
E 240 T (210.261) (M 112.911)		Gasolina	RWD	2398	125	170	06.97-03.03	■
E 280 T (210.263) (M 112.921)	-12/97	Gasolina	RWD	2799	150	204	12.96-03.03	■
E 280 T 4-matic (210.281) (M 112.921)	-12/97	Gasolina	4WD	2799	150	204	12.96-03.03	■
E 320 T (210.265) (M 112.941)	-12/97	Gasolina	RWD	3199	165	224	12.96-03.03	■
E 320 T 4-matic (210.282) (M 112.941)	-12/97	Gasolina	4WD	3199	165	224	12.96-03.03	■
E 420 T (210.272) (M 119.985)		Gasolina	RWD	4196	205	279	06.96-06.97	■
E 430 T (210.270) (M 113.940)	-12/97	Gasolina	RWD	4266	205	279	06.97-03.03	■
E 250 T D (210.210) (OM 605.912)	-12/97	Diesel	RWD	2497	83	113	06.96-07.99	■
E 270 T CDI (210.216) (OM 612.961)		Diesel	RWD	2685	120	163	02.00-03.03	■
E 270 T CDI (210.216) (OM 612.961)		Diesel	RWD	2685	125	170	07.99-03.03	■
E 290 T Turbo-D (210.217) (OM 602.982)	-12/97	Diesel	RWD	2874	95	129	06.96-07.99	■
E 300 T Turbo-D (210.225) (OM 606.962)	-12/97	Diesel	RWD	2996	130	177	12.96-07.99	■
E 320 T CDI (210.226) (OM 613.961)		Diesel	RWD	3222	145	197	07.99-03.03	■
SLK-Class (R170) 04.96-04.04				Convertible (Sports car-S Segment)				
320 (170.465) (M 112.947)		Gasolina	RWD	3199	160	218	03.00-04.04	■