

LISTA DE APLICACIONES - BUYERS GUIDE

181592



8 424073 087027

Qty: 300

Weight: 2.053

| O.E.M. | MAKE |
|---------------|----------|
| 16 05 080 | OPEL |
| 16 05 099 | OPEL |
| 16 05 177 | OPEL |
| 16 05 252 | OPEL |
| 16 05 264 | OPEL |
| 16 05 456 | OPEL |
| 16 05 992 | OPEL |
| 16 05 996 | OPEL |
| 16 05 997 | OPEL |
| 16 05 998 | OPEL |
| 86 60 004 792 | RENAULT |
| 86 71 019 122 | RENAULT |
| 93 176 115 | VAUXHALL |
| 93 176 429 | VAUXHALL |
| 93 179 707 | VAUXHALL |
| 93 179 708 | VAUXHALL |
| 93 181 189 | OPEL |
| 93 186 713 | VAUXHALL |
| 93 189 698 | OPEL |
| 93 192 578 | VAUXHALL |
| 9319 1893 | SATURN |
| 95 514 416 | VAUXHALL |
| 95 516 194 | VAUXHALL |

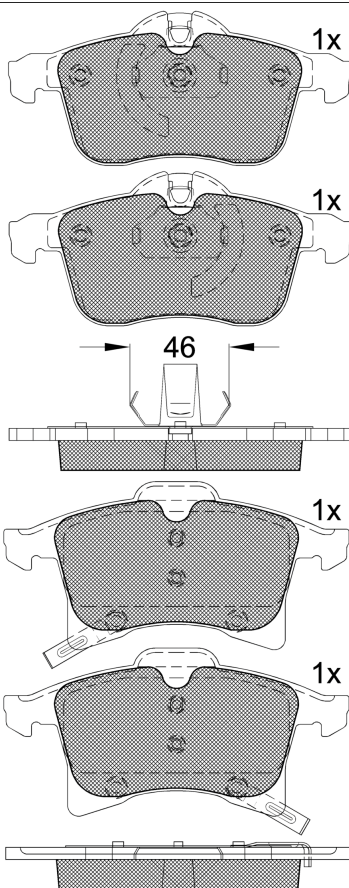

181592



90R-01111/788



Ate - Teves

154.9x69.76x20.4

156.1x76x20.4

WVA

23832

23833

23844

FMSI

D1361-8470

MAKE

CHEVROLET

HOLDEN

LADA

OPEL

SATURN

SUBARU

VAUXHALL



| Trac. | CC | Kw | CV |
|-------|----|----|----|
|-------|----|----|----|



Front / Rear

CHEVROLET

COMBO 04.01-

Van (LCVs-N1 Segment)

| | | | | | | | | |
|---------------------|-------------------|----------|-----|------|----|----|-------------|---|
| 1.3 CDTi (Z 13 DTJ) | increased payload | Gasolina | FWD | 1248 | 55 | 75 | 10.06-10.12 | ■ |
| 1.4 (Z 14 EXP) | increased payload | Gasolina | FWD | 1364 | 66 | 90 | 10.06-10.12 | ■ |

MERIVA 02.02-07.12

MPV (Mini MPV-M1 Segment)

| | | | | | | | |
|--------------------------------------|---------------|-----|------|----|-----|-------------|---|
| 1.4 | Gasolina | FWD | 1389 | 73 | 99 | 07.07-07.12 | ■ |
| 1.4 Flex | Gasolina | FWD | 1389 | 77 | 105 | 07.07-07.12 | ■ |
| 1.4 Flex | Gasolina | FWD | 1398 | 73 | 99 | 09.08-07.12 | ■ |
| 1.8 | Gasolina | FWD | 1796 | 75 | 102 | 02.02- | ■ |
| 1.8 Flex | Gasolina | FWD | 1796 | 77 | 105 | 11.03-08.05 | ■ |
| 1.8 | Gasolina | FWD | 1796 | 78 | 106 | 01.04-07.12 | ■ |
| 1.8 | Gasolina | FWD | 1796 | 82 | 111 | 03.03-07.12 | ■ |
| 1.8 (75) (L79(110CUL4)) | Gasolina | FWD | 1796 | 90 | 122 | 03.03-02.06 | ■ |
| 1.8 | Gasolina | FWD | 1796 | 92 | 125 | 05.03-05.08 | ■ |
| 1.8 Joy Flexpower(75) (LMD(110CUL4)) | Gasol./Etanol | FWD | 1796 | 81 | 109 | 11.03-08.05 | ■ |
| 1.8 Flex (75) | Gasol./Etanol | FWD | 1796 | 84 | 114 | 09.05-07.12 | ■ |
| 1.7 D | Diesel | RWD | 1686 | 55 | 75 | 08.02-01.08 | ■ |

VIVA 09.03-03.08

Saloon (Compact car-C Segment)

| | | | | | | | |
|-----------|----------|-----|------|----|-----|-------------|---|
| 1.8 | Gasolina | FWD | 1796 | 90 | 122 | 09.03-03.08 | ■ |
| 1.8 (2H9) | Gasolina | FWD | 1796 | 92 | 125 | 09.03-03.08 | ■ |

ZAFIRA II 07.05-

MPV (Compact MPV-M1 Segment)

| | | | | | | | |
|----------|----------|-----|------|----|-----|-------------|---|
| 2.0 | Gasolina | FWD | 1998 | 94 | 128 | 08.05-01.09 | ■ |
| 2.0 Flex | Gasolina | FWD | 1998 | 94 | 128 | 08.05-01.09 | ■ |

LISTA DE APLICACIONES - BUYERS GUIDE

| | | | | | | | | | |
|--|-------------------|---------------|-----|------|--|-----|-------------|---|--|
| 2.2 (Z 22 YH) | | Gasolina | FWD | 2198 | 110 | 150 | 07.05- | ■ | |
| ZAFIRA / NABIRA (F75) 02.99-12.12 | | | | | MPV (Compact MPV-M1 Segment) | | | | |
| 1.8 (C 18 YE) | | Gasolina | FWD | 1796 | 81 | 110 | 02.99-07.01 | ■ | |
| 1.8 | | Gasolina | FWD | 1796 | 92 | 125 | 07.00-06.05 | ■ | |
| 2.0 (LE4(122CUL4)) | | Gasolina | FWD | 1998 | 85 | 116 | 04.01-07.04 | ■ | |
| 2.0 (X 20 XE) | | Gasolina | FWD | 1998 | 89 | 121 | 08.04-12.12 | ■ | |
| 2.0 Flexpower | | Gasolina | FWD | 1998 | 94 | 128 | 08.04-07.05 | ■ | |
| 2.0 (C 20 SEL) | | Gasolina | FWD | 1998 | 100 | 136 | 04.01-07.12 | ■ | |
| 2.0 (L34(122CUL4)) | | Gasolina | FWD | 1998 | 100 | 136 | 04.01-07.12 | ■ | |
| 2.2 | | Gasolina | FWD | 2198 | 91 | 124 | 04.01-07.04 | ■ | |
| 2.2 (Z 22 SE) | | Gasolina | FWD | 2198 | 108 | 147 | 09.01-12.05 | ■ | |
| 2.2 (Z 22 SE) | | Gasolina | FWD | 2198 | 110 | 150 | 09.01-12.05 | ■ | |
| 2.2 (Z 22 YH) | | Gasolina | FWD | 2198 | 110 | 150 | 09.05-12.06 | ■ | |
| 2.0 Flex (LMC(122CUL4)) | | Gasol./Etanol | FWD | 1998 | 103 | 140 | 02.09-03.12 | ■ | |
| HOLDEN | | | | | | | | | |
| ASTRA (TS) 02.01-12.06 | | | | | Convertible (Compact car-C Segment) | | | | |
| 1.8 i | | Gasolina | FWD | 2198 | 108 | 147 | 06.02-12.06 | ■ | |
| ASTRA (AH) 12.04- | | | | | Estate (Compact car-C Segment) | | | | |
| 1.8 i | | Gasolina | FWD | 1796 | 92 | 125 | 07.05-03.07 | ■ | |
| 1.8 i | | Gasolina | FWD | 1796 | 103 | 140 | 04.07-03.10 | ■ | |
| 1.9 CDTI | | Diesel | RWD | 1910 | 88 | 120 | 08.08-03.10 | ■ | |
| ASTRA (TS) 02.98-10.05 | | | | | Hatchback (Compact car-C Segment) | | | | |
| 1.8 i | vehicles with ABS | Gasolina | FWD | 1796 | 85 | 116 | 02.98-08.00 | ■ | |
| 1.8 i | vehicles with ABS | Gasolina | FWD | 1796 | 92 | 125 | 09.00-10.04 | ■ | |
| 1.8 i | | Gasolina | FWD | 1796 | 92 | 123 | 07.05-03.07 | ■ | |
| 1.8 i | | Gasolina | FWD | 1796 | 103 | 140 | 04.07-03.10 | ■ | |
| 2.2 i | | Gasolina | FWD | 2198 | 108 | 147 | 09.00-07.04 | ■ | |
| 2.2 i | | Gasolina | FWD | 2198 | 109 | 146 | 12.06-03.08 | ■ | |
| 1.9 CDTI | | Diesel | RWD | 1910 | 88 | 120 | 06.06-03.10 | ■ | |
| 1.9 CDTI | | Diesel | RWD | 1910 | 110 | 150 | 06.06-03.10 | ■ | |
| ASTRA (TS) 02.98-10.05 | | | | | Saloon (Compact car-C Segment) | | | | |
| 1.8 i | vehicles with ABS | Gasolina | FWD | 1796 | 85 | 116 | 02.98-08.00 | ■ | |
| 1.8 i | vehicles with ABS | Gasolina | FWD | 1796 | 92 | 125 | 09.00-10.04 | ■ | |
| ASTRA SPORTSBACK (AH) 07.05-03.10 | | | | | Coupe (Compact car-C Segment) | | | | |
| 1.8 i | | Gasolina | FWD | 1796 | 92 | 123 | 07.05-03.08 | ■ | |
| 1.8 i | | Gasolina | FWD | 1796 | 103 | 140 | 04.07-03.10 | ■ | |
| 2.0 i Turbo | | Gasolina | FWD | 1998 | 147 | 200 | 06.06-03.10 | ■ | |
| 2.2 | | Gasolina | FWD | 2198 | 110 | 150 | 12.06-03.08 | ■ | |
| 2.2 i | | Gasolina | FWD | 2198 | 110 | 150 | 12.06-03.10 | ■ | |
| ASTRA TWINTOP (AH) 03.08-03.10 | | | | | Convertible (Compact car-C Segment) | | | | |
| 2.2 i | | Gasolina | FWD | 2198 | 110 | 150 | 03.08-03.10 | ■ | |
| COMBO (XC) 08.01- | | | | | Van (LCVs-N1 Segment) | | | | |
| 1.4 i | increased payload | Gasolina | FWD | 1364 | 66 | 90 | 04.05-12.12 | ■ | |
| 1.6 i | increased payload | Gasolina | FWD | 1598 | 62 | 84 | 09.02-04.05 | ■ | |
| ZAFIRA (TT) 07.00-02.06 | | | | | MPV (Compact MPV-M1 Segment) | | | | |
| 2.2 i | | Gasolina | FWD | 2198 | 108 | 147 | 06.01-02.06 | ■ | |
| LADA | | | | | | | | | |

LISTA DE APLICACIONES - BUYERS GUIDE

| KALINA (1119) 10.04-12.13 | | | | | Hatchback (Supermini car-B Segment) | | | |
|--|-------------------|------------------|-----|------|--|-----|-------------|---|
| 1.4 16V LPG (11194) | 01/10- | Gasol./Gas (LPG) | FWD | 1390 | 65 | 88 | 11.08-12.13 | ■ |
| OPEL | | | | | | | | |
| ADAM (M13) 10.12- | | | | | Hatchback (City car-A Segment) | | | |
| 1.0 | Rim 16, discØ 308 | Gasolina | FWD | 996 | 50 | 68 | 07.13- | ■ |
| 1.0 (B 10 XFL) | Rim 16, discØ 308 | Gasolina | FWD | 999 | 66 | 90 | 07.14-11.18 | ■ |
| 1.0 (D 10 XFL) | Rim 16, discØ 308 | Gasolina | FWD | 999 | 66 | 90 | 07.14-11.18 | ■ |
| 1.0 (B 10 XFT) | Rim 16, discØ 308 | Gasolina | FWD | 999 | 85 | 115 | 07.14-11.18 | ■ |
| 1.0 (D 10 XFT) | Rim 16, discØ 308 | Gasolina | FWD | 999 | 85 | 115 | 07.14-11.18 | ■ |
| 1.2 (A 12 XEL) | Rim 16, discØ 308 | Gasolina | FWD | 1229 | 51 | 69 | 10.12-05.19 | ■ |
| 1.2 (B 12 XEL) | Rim 16, discØ 308 | Gasolina | FWD | 1229 | 51 | 69 | 10.12-05.19 | ■ |
| 1.2 (D 12 XEL) | Rim 16, discØ 308 | Gasolina | FWD | 1229 | 51 | 69 | 10.12-05.19 | ■ |
| 1.2 | Rim 16, discØ 308 | Gasolina | FWD | 1242 | 69 | 94 | 07.13- | ■ |
| 1.4 S (B 14 NEH) | Rim 16, discØ 308 | Gasolina | FWD | 1364 | 110 | 150 | 11.14-05.19 | ■ |
| 1.4 S (D 14 NEH) | Rim 16, discØ 308 | Gasolina | FWD | 1364 | 110 | 150 | 11.14-05.19 | ■ |
| 1.4 (A 14 XEL) | Rim 16, discØ 308 | Gasolina | FWD | 1398 | 64 | 87 | 10.12-05.19 | ■ |
| 1.4 (B 14 XEL) | Rim 16, discØ 308 | Gasolina | FWD | 1398 | 64 | 87 | 10.12-05.19 | ■ |
| 1.4 (D 14 XEL) | Rim 16, discØ 308 | Gasolina | FWD | 1398 | 64 | 87 | 10.12-05.19 | ■ |
| 1.4 (A 14 XER) | Rim 16, discØ 308 | Gasolina | FWD | 1398 | 74 | 101 | 10.12-05.19 | ■ |
| 1.4 (B 14 XER) | Rim 16, discØ 308 | Gasolina | FWD | 1398 | 74 | 101 | 10.12-05.19 | ■ |
| 1.4 (D 14 XER) | Rim 16, discØ 308 | Gasolina | FWD | 1398 | 74 | 101 | 10.12-05.19 | ■ |
| 1.4 LPG (A 14 XEL) | Rim 16, discØ 308 | Gasol./Gas (LPG) | FWD | 1398 | 64 | 87 | 07.13-11.18 | ■ |
| 1.4 LPG (B 14 XEL) | Rim 16, discØ 308 | Gasol./Gas (LPG) | FWD | 1398 | 64 | 87 | 07.13-11.18 | ■ |
| 1.4 LPG (D 14 XEL) | Rim 16, discØ 308 | Gasol./Gas (LPG) | FWD | 1398 | 64 | 87 | 07.13-11.18 | ■ |
| ASTRA F CLASSIC (T92) 01.98-01.05 | | | | | Estate (Compact car-C Segment) | | | |
| 1.4 Comfort | | Gasolina | FWD | 1364 | 66 | 90 | 09.03-01.05 | ■ |
| ASTRA G (T98) 03.01-10.05 | | | | | Convertible (Compact car-C Segment) | | | |
| 1.8 16V (F67) (Z 18 XE) | | Gasolina | FWD | 1796 | 92 | 125 | 03.01-10.05 | ■ |
| 2.0 OPC (F67) (Z 20 LET) | | Gasolina | FWD | 1998 | 141 | 192 | 03.02-10.05 | ■ |
| 2.0 16V Turbo (F67) (Z 20 LET) | | Gasolina | FWD | 1998 | 147 | 200 | 11.02-10.05 | ■ |
| 2.2 16V (F67) (Z 22 SE) | | Gasolina | FWD | 2198 | 108 | 147 | 03.01-10.05 | ■ |
| 2.2 DTI (F67) (Y 22 DTR) | | Diesel | FWD | 2172 | 92 | 125 | 09.02-10.05 | ■ |
| ASTRA G (T98) 03.00-06.06 | | | | | Coupe (Compact car-C Segment) | | | |
| 1.6 16V (F07) (Z 16 XE) | | Gasolina | FWD | 1598 | 74 | 101 | 03.00-05.05 | ■ |
| 1.6 16V (F07) (Z 16 XEP) | | Gasolina | FWD | 1598 | 76 | 103 | 03.00-05.05 | ■ |
| 1.8 16V (F07) (X 18 XE1) | | Gasolina | FWD | 1796 | 85 | 116 | 03.00-10.00 | ■ |
| 1.8 16V (F07) (Z 18 XE) | | Gasolina | FWD | 1796 | 92 | 125 | 09.00-05.05 | ■ |
| 2.0 16V Turbo (F07) (Z 20 LET) | | Gasolina | FWD | 1998 | 141 | 192 | 08.01-05.05 | ■ |
| 2.0 16V Turbo (F07) (Z 20 LET) | | Gasolina | FWD | 1998 | 147 | 200 | 11.02-05.05 | ■ |
| 2.2 16V (F07) (Z 22 SE) | | Gasolina | FWD | 2198 | 108 | 147 | 09.00-05.05 | ■ |
| 2.2 DTI (F07) (Y 22 DTR) | | Diesel | FWD | 2172 | 92 | 125 | 09.02-05.05 | ■ |
| ASTRA G (F70) 09.98-04.05 | | | | | Estate Van (Compact car-C Segment) | | | |
| 2.0 DI (F70) (X 20 DTL) | vehicles with ABS | Diesel | FWD | 1995 | 60 | 82 | 01.99-04.05 | ■ |
| 2.0 DI (F70) (Y 20 DTL) | vehicles with ABS | Diesel | FWD | 1995 | 60 | 82 | 01.99-04.05 | ■ |
| 2.0 DTI (F70) (Y 20 DTH) | vehicles with ABS | Diesel | FWD | 1995 | 74 | 101 | 09.00-04.05 | ■ |

LISTA DE APLICACIONES - BUYERS GUIDE

| ASTRA G (T98) 02.98-07.05 | | | | | | Estate (Compact car-C Segment) | | | |
|-----------------------------------|-------------------|------------------|-----|------|-----|---|-------------|---|--|
| 1.8 16V (F35) (X 18 XE1) | vehicles with ABS | Gasolina | FWD | 1796 | 85 | 116 | 02.98-09.00 | ■ | |
| 1.8 16V (F35) (Z 18 XE) | vehicles with ABS | Gasolina | FWD | 1796 | 92 | 125 | 09.00-07.04 | ■ | |
| 2.0 16V (F35) (X 20 XEV) | | Gasolina | FWD | 1998 | 100 | 136 | 02.98-07.04 | ■ | |
| 2.0 OPC (F35) (Z 20 LET) | | Gasolina | FWD | 1998 | 141 | 192 | 09.02-07.04 | ■ | |
| 2.0 OPC (F35) (Z 20 LET) | | Gasolina | FWD | 1998 | 147 | 200 | 11.02-07.04 | ■ | |
| 2.2 16V (F35) (Z 22 SE) | | Gasolina | FWD | 2198 | 108 | 147 | 03.01-07.04 | ■ | |
| 1.6 CNG (F35) (Z 16 YNG) | | Gasol./Gas (CNG) | FWD | 1598 | 71 | 97 | 03.03-07.04 | ■ | |
| 2.0 DI (F35) (X 20 DTL) | | Diesel | FWD | 1995 | 60 | 82 | 02.98-07.04 | ■ | |
| 2.0 DI (F35) (Y 20 DTL) | | Diesel | FWD | 1995 | 60 | 82 | 02.98-07.04 | ■ | |
| 2.0 DTI 16V (F35) (Y 20 DTH) | vehicles with ABS | Diesel | FWD | 1995 | 74 | 101 | 08.99-07.04 | ■ | |
| 2.2 DTI (F35) (Y 22 DTR) | | Diesel | FWD | 2172 | 86 | 117 | 09.02-07.04 | ■ | |
| 2.2 DTI (F35) (Y 22 DTR) | | Diesel | FWD | 2172 | 92 | 125 | 09.02-07.04 | ■ | |
| ASTRA G (T98) 02.98-12.09 | | | | | | Hatchback (Compact car-C Segment) | | | |
| 1.8 (F08, F48) | vehicles with ABS | Gasolina | FWD | 1796 | 81 | 110 | 02.03-01.04 | ■ | |
| 1.8 16V (F08, F48) (X 18 XE1) | vehicles with ABS | Gasolina | FWD | 1796 | 85 | 116 | 02.98-09.00 | ■ | |
| 1.8 16V (F08, F48) (Z 18 XE) | vehicles with ABS | Gasolina | FWD | 1796 | 92 | 125 | 09.00-01.05 | ■ | |
| 2.0 16V (F08, F48) (X 20 XEV) | | Gasolina | FWD | 1998 | 100 | 136 | 02.98-01.05 | ■ | |
| 2.0 OPC (F08, F48) (Z 20 LET) | | Gasolina | FWD | 1998 | 141 | 192 | 09.02-01.05 | ■ | |
| 2.0 OPC (F08, F48) (Z 20 LET) | | Gasolina | FWD | 1998 | 147 | 200 | 11.02-01.05 | ■ | |
| 2.2 16V (F08, F48) (Z 22 SE) | | Gasolina | FWD | 2198 | 108 | 147 | 06.00-01.05 | ■ | |
| 2.0 DI (F08, F48) (X 20 DTL) | | Diesel | FWD | 1995 | 60 | 82 | 02.98-01.05 | ■ | |
| 2.0 DI (F08, F48) (Y 20 DTL) | | Diesel | FWD | 1995 | 60 | 82 | 02.98-01.05 | ■ | |
| 2.0 DTI 16V (F08, F48) (Y 20 DTH) | vehicles with ABS | Diesel | FWD | 1995 | 74 | 101 | 08.99-01.05 | ■ | |
| 2.2 DTI (F08, F48) (Y 22 DTR) | | Diesel | FWD | 2172 | 86 | 117 | 09.02-01.05 | ■ | |
| 2.2 DTI (F08, F48) (Y 22 DTR) | | Diesel | FWD | 2172 | 92 | 125 | 09.02-01.05 | ■ | |
| ASTRA G (T98) 03.98-12.09 | | | | | | Saloon (Compact car-C Segment) | | | |
| 1.8 | vehicles with ABS | Gasolina | FWD | 1796 | 81 | 110 | 02.03-01.05 | ■ | |
| 1.8 16V (F69) (X 18 XE1) | vehicles with ABS | Gasolina | FWD | 1796 | 85 | 116 | 09.98-09.00 | ■ | |
| 1.8 16V (F69) (Z 18 XE) | vehicles with ABS | Gasolina | FWD | 1796 | 92 | 125 | 06.00-01.05 | ■ | |
| 2.0 16V (F69) (X 20 XEV) | | Gasolina | FWD | 1998 | 100 | 136 | 09.98-01.05 | ■ | |
| 2.2 16V (F69) (Z 22 SE) | | Gasolina | FWD | 2198 | 108 | 147 | 03.01-01.05 | ■ | |
| 2.0 DI (F69) (X 20 DTL) | | Diesel | FWD | 1995 | 60 | 82 | 09.98-01.05 | ■ | |
| 2.0 DI (F69) (Y 20 DTL) | | Diesel | FWD | 1995 | 60 | 82 | 09.98-01.05 | ■ | |
| 2.0 DTI 16V (F69) (Y 20 DTH) | vehicles with ABS | Diesel | FWD | 1995 | 74 | 101 | 08.99-01.05 | ■ | |
| 2.2 DTI (F69) (Y 22 DTR) | | Diesel | FWD | 2172 | 86 | 117 | 09.02-01.05 | ■ | |
| 2.2 DTI (F69) (Y 22 DTR) | | Diesel | FWD | 2172 | 92 | 125 | 09.02-01.05 | ■ | |
| ASTRA H (L70) 02.04-10.14 | | | | | | Estate Van (Compact car-C Segment) | | | |
| 1.4 EcoTec (L70) (Z 14 XEP) | | Gasolina | FWD | 1364 | 66 | 90 | 12.04-12.12 | ■ | |
| 1.6 EcoTec (L70) (Z 16 XEP) | | Gasolina | FWD | 1598 | 76 | 103 | 02.04-11.04 | ■ | |
| 1.6 EcoTec (L70) (Z 16 XER) | | Gasolina | FWD | 1598 | 85 | 116 | 10.06-12.10 | ■ | |
| 1.3 CDTI (L70) (Z 13 DTH) | | Diesel | FWD | 1248 | 66 | 90 | 08.05-10.10 | ■ | |
| 1.7 CDTI (L70) (Z 17 DTL) | | Diesel | FWD | 1686 | 59 | 80 | 12.04-07.07 | ■ | |
| 1.7 CDTI (L70) (Z 17 DTH) | | Diesel | FWD | 1686 | 74 | 101 | 03.04-10.10 | ■ | |
| 1.7 CDTI (L70) (A 17 DTJ) | | Diesel | FWD | 1686 | 81 | 110 | 02.07-10.14 | ■ | |
| 1.7 CDTI (L70) (Z 17 DTJ) | | Diesel | FWD | 1686 | 81 | 110 | 02.07-10.14 | ■ | |
| 1.7 CDTI (L70) (A 17 DTR) | | Diesel | FWD | 1686 | 92 | 125 | 02.07-10.10 | ■ | |
| 1.7 CDTI (L70) (Z 17 DTR) | | Diesel | FWD | 1686 | 92 | 125 | 02.07-10.10 | ■ | |

LISTA DE APLICACIONES - BUYERS GUIDE

| | | | | | | | | | |
|----------------------------------|--------|----------------------|-----|------|-----|-----|--|---|--|
| 1.9 CDTI (L70) (Z 19 DTL) | | Diesel | FWD | 1910 | 74 | 101 | 08.05-12.12 | ■ | |
| 1.9 CDTI (L70) (Z 19 DT) | | Diesel | FWD | 1910 | 88 | 120 | 09.05-10.10 | ■ | |
| 1.9 CDTI 16V (L70) (Z 19 DTJ) | | Diesel | FWD | 1910 | 88 | 120 | 08.04-10.10 | ■ | |
| 1.9 CDTI (L70) (Z 19 DTH) | | Diesel | FWD | 1910 | 110 | 150 | 09.04-10.10 | ■ | |
| ASTRA H (A04) 08.04-10.10 | | | | | | | Estate (Compact car-C Segment) | | |
| 1.4 (L35) (Z 14 XEL) | | Gasolina | FWD | 1364 | 55 | 75 | 08.04-10.10 | ■ | |
| 1.4 (L35) (Z 14 XEP) | -12/09 | Gasolina | FWD | 1364 | 66 | 90 | 08.04-10.10 | ■ | |
| 1.6 CNG | -12/09 | Gasolina | FWD | 1598 | 69 | 94 | 11.05- | ■ | |
| 1.6 (L35) (Z 16 XE1) | -12/09 | Gasolina | FWD | 1598 | 77 | 105 | 08.04-10.10 | ■ | |
| 1.6 (L35) (Z 16 XEP) | -12/09 | Gasolina | FWD | 1598 | 77 | 105 | 08.04-10.10 | ■ | |
| 1.6 (L35) (A 16 XER) | -12/09 | Gasolina | FWD | 1598 | 85 | 116 | 11.06-10.10 | ■ | |
| 1.6 (L35) (Z 16 XER) | -12/09 | Gasolina | FWD | 1598 | 85 | 116 | 11.06-10.10 | ■ | |
| 1.6 Turbo (L35) (A 16 LET) | -12/09 | Gasolina | FWD | 1598 | 132 | 180 | 02.07-10.10 | ■ | |
| 1.6 Turbo (L35) (Z 16 LET) | -12/09 | Gasolina | FWD | 1598 | 132 | 180 | 02.07-10.10 | ■ | |
| 1.8 (L35) (Z 18 XE) | -12/09 | Gasolina | FWD | 1796 | 92 | 125 | 08.04-10.10 | ■ | |
| 1.8 (L35) (A 18 XER) | -12/09 | Gasolina | FWD | 1796 | 103 | 140 | 11.05-10.10 | ■ | |
| 1.8 (L35) (Z 18 XER) | -12/09 | Gasolina | FWD | 1796 | 103 | 140 | 11.05-10.10 | ■ | |
| 2.0 Turbo (L35) (Z 20 LEL) | -12/09 | Gasolina | FWD | 1998 | 125 | 170 | 08.04-10.10 | ■ | |
| 2.0 Turbo (L35) (Z 20 LER) | -12/09 | Gasolina | FWD | 1998 | 147 | 200 | 09.04-10.10 | ■ | |
| 1.4 LPG (L35) (Z 14 XEP) | -12/09 | Gasol./G as (LPG) | FWD | 1364 | 66 | 90 | 08.09-10.10 | ■ | |
| 1.6 LPG (L35) (Z 16 XER) | -12/09 | Gasol./G as (LPG) | FWD | 1598 | 85 | 116 | 08.09-10.10 | ■ | |
| 1.3 CDTI (L35) (Z 13 DTH) | -12/09 | Diesel | FWD | 1248 | 66 | 90 | 08.05-10.10 | ■ | |
| 1.7 CDTI (L35) (Z 17 DTL) | -12/09 | Diesel | FWD | 1686 | 59 | 80 | 08.04-10.10 | ■ | |
| 1.7 CDTI (L35) (Z 17 DTH) | -12/09 | Diesel | FWD | 1686 | 74 | 101 | 08.04-10.10 | ■ | |
| 1.7 CDTI (L35) (A 17 DTJ) | -12/09 | Diesel | FWD | 1686 | 81 | 110 | 12.08-10.10 | ■ | |
| 1.7 CDTI (L35) (Z 17 DTJ) | -12/09 | Diesel | FWD | 1686 | 81 | 110 | 12.08-10.10 | ■ | |
| 1.7 CDTI (L35) (A 17 DTR) | -12/09 | Diesel | FWD | 1686 | 92 | 125 | 04.07-10.10 | ■ | |
| 1.7 CDTI (L35) (Z 17 DTR) | -12/09 | Diesel | FWD | 1686 | 92 | 125 | 04.07-10.10 | ■ | |
| 1.9 CDTI (L35) (Z 19 DTL) | -12/09 | Diesel | FWD | 1910 | 74 | 100 | 09.05-10.10 | ■ | |
| 1.9 CDTI (L35) (Z 19 DT) | -12/09 | Diesel | FWD | 1910 | 88 | 120 | 09.05-10.10 | ■ | |
| 1.9 CDTI 16V (L35) (Z 19 DTJ) | -12/09 | Diesel | FWD | 1910 | 88 | 120 | 08.04-10.10 | ■ | |
| 1.9 CDTI | -12/09 | Diesel | RWD | 1910 | 103 | 140 | 12.04- | ■ | |
| 1.9 CDTI (L35) (Z 19 DTH) | -12/09 | Diesel | FWD | 1910 | 110 | 150 | 09.04-10.10 | ■ | |
| ASTRA H (A04) 01.04-01.11 | | | | | | | Hatchback (Compact car-C Segment) | | |
| 1.2 | -12/09 | Gasolina | FWD | 1199 | 48 | 65 | 10.06- | ■ | |
| 1.2 (L48) (Z 12 XEP) | -12/09 | Gasolina | FWD | 1229 | 59 | 80 | 08.05-10.10 | ■ | |
| 1.4 (L48) (Z 14 XEL) | | Gasolina | FWD | 1364 | 55 | 75 | 04.04-10.04 | ■ | |
| 1.4 | | Gasolina | FWD | 1364 | 59 | 80 | 04.04-10.04 | ■ | |
| 1.4 (L48) (Z 14 XEP) | -12/09 | Gasolina | FWD | 1364 | 66 | 90 | 03.04-10.10 | ■ | |
| 1.6 CNG | -12/09 | Gasolina | FWD | 1598 | 69 | 94 | 11.05- | ■ | |
| 1.6 (L48) (Z 16 XE1) | -12/09 | Gasolina | FWD | 1598 | 77 | 105 | 03.04-10.10 | ■ | |
| 1.6 (L48) (Z 16 XEP) | -12/09 | Gasolina | FWD | 1598 | 77 | 105 | 03.04-10.10 | ■ | |
| 1.6 (L48) (A 16 XER) | -12/09 | Gasolina | FWD | 1598 | 85 | 116 | 11.06-09.09 | ■ | |
| 1.6 (L48) (Z 16 XER) | -12/09 | Gasolina | FWD | 1598 | 85 | 116 | 11.06-09.09 | ■ | |
| 1.6 Turbo (L48) (A 16 LET) | -12/09 | Gasolina | FWD | 1598 | 132 | 180 | 02.07-10.10 | ■ | |
| 1.6 Turbo (L48) (Z 16 LET) | -12/09 | Gasolina | FWD | 1598 | 132 | 180 | 02.07-10.10 | ■ | |
| 1.8 (L48) (Z 18 XE) | -12/09 | Gasolina | FWD | 1796 | 92 | 125 | 01.04-10.10 | ■ | |
| 1.8 (L48) (A 18 XER) | -12/09 | Gasolina | FWD | 1796 | 103 | 140 | 01.06-10.10 | ■ | |
| 1.8 (L48) (Z 18 XER) | -12/09 | Gasolina | FWD | 1796 | 103 | 140 | 01.06-10.10 | ■ | |
| 2.0 Turbo (L48) (Z 20 LEL) | -12/09 | Gasolina | FWD | 1998 | 125 | 170 | 03.04-10.10 | ■ | |

LISTA DE APLICACIONES - BUYERS GUIDE

| | | | | | | | | |
|--|--------|------------------|-----|--|-----|-----|-------------|---|
| 2.0 Turbo (L48) (Z 20 LER) | -12/09 | Gasolina | FWD | 1998 | 147 | 200 | 09.04-10.10 | ■ |
| 2.0 Turbo (L48) (Z 20 LEH) | -12/09 | Gasolina | FWD | 1998 | 177 | 240 | 03.05-10.10 | ■ |
| 1.4 LPG (L48) (Z 14 XEP) | | Gasol./Gas (LPG) | FWD | 1364 | 66 | 90 | 08.09-10.10 | ■ |
| 1.3 CDTI (L48) (Z 13 DTH) | -12/09 | Diesel | FWD | 1248 | 66 | 90 | 08.05-10.10 | ■ |
| 1.7 CDTI (L48) (Z 17 DTL) | -12/09 | Diesel | FWD | 1686 | 59 | 80 | 03.04-10.10 | ■ |
| 1.7 CDTI (L48) (Z 17 DTH) | -12/09 | Diesel | FWD | 1686 | 74 | 100 | 03.04-10.10 | ■ |
| 1.7 CDTI (L48) (A 17 DTJ) | -12/09 | Diesel | FWD | 1686 | 81 | 110 | 04.07-09.09 | ■ |
| 1.7 CDTI (L48) (Z 17 DTJ) | -12/09 | Diesel | FWD | 1686 | 81 | 110 | 04.07-09.09 | ■ |
| 1.7 CDTI (L48) (A 17 DTR) | -12/09 | Diesel | FWD | 1686 | 92 | 125 | 04.07-09.09 | ■ |
| 1.7 CDTI (L48) (Z 17 DTR) | -12/09 | Diesel | FWD | 1686 | 92 | 125 | 04.07-09.09 | ■ |
| 1.9 CDTI (L48) (Z 19 DTL) | -12/09 | Diesel | FWD | 1910 | 74 | 100 | 09.05-10.10 | ■ |
| 1.9 CDTI (L48) (Z 19 DT) | -12/09 | Diesel | FWD | 1910 | 88 | 120 | 06.04-10.10 | ■ |
| 1.9 CDTI 16V (L48) (Z 19 DTJ) | -12/09 | Diesel | FWD | 1910 | 88 | 120 | 04.04-10.10 | ■ |
| 1.9 CDTI (L48) (Z 19 DTH) | -12/09 | Diesel | FWD | 1910 | 110 | 150 | 09.04-10.10 | ■ |
| ASTRA H (A04) 02.07-12.13 | | | | Saloon (Compact car-C Segment) | | | | |
| 1.4 (L69) (Z 14 XEP) | | Gasolina | FWD | 1364 | 66 | 90 | 02.07-06.10 | ■ |
| 1.6 (L69) (Z 16 XEP) | | Gasolina | FWD | 1598 | 77 | 105 | 02.07-06.10 | ■ |
| 1.6 (L69) (Z 16 XER) | -12/09 | Gasolina | FWD | 1598 | 85 | 116 | 09.08-06.10 | ■ |
| 1.8 (L69) (A 18 XER) | -12/09 | Gasolina | FWD | 1796 | 103 | 140 | 02.07-06.10 | ■ |
| 1.8 (L69) (Z 18 XER) | -12/09 | Gasolina | FWD | 1796 | 103 | 140 | 02.07-06.10 | ■ |
| 1.3 CDTi (L69) (Z 13 DTH) | -12/09 | Diesel | FWD | 1248 | 66 | 90 | 02.07-10.10 | ■ |
| 1.7 CDTi (L69) (Z 17 DTH) | -12/09 | Diesel | FWD | 1686 | 74 | 101 | 02.07-10.10 | ■ |
| 1.7 CDTi (L69) (Z 17 DTJ) | -12/09 | Diesel | FWD | 1686 | 81 | 110 | 02.07-06.10 | ■ |
| ASTRA H CLASSIC (A04) 01.09-05.14 | | | | Estate (Compact car-C Segment) | | | | |
| 1.4 (L35) (Z 14 XEP) | | Gasolina | FWD | 1364 | 66 | 90 | 01.09-05.14 | ■ |
| 1.6 (L35) (Z 16 XER) | | Gasolina | FWD | 1598 | 85 | 116 | 01.09-05.14 | ■ |
| 1.8 (L35) (Z 18 XER) | | Gasolina | FWD | 1796 | 103 | 140 | 01.12-05.14 | ■ |
| 1.7 CDTI (L35) (Z 17 DTJ) | | Diesel | FWD | 1686 | 81 | 110 | 01.09-05.14 | ■ |
| 1.7 CDTI (L35) (A 17 DTR) | | Diesel | FWD | 1686 | 92 | 125 | 01.09-05.14 | ■ |
| 1.7 CDTI (L35) (Z 17 DTR) | | Diesel | FWD | 1686 | 92 | 125 | 01.09-05.14 | ■ |
| ASTRA H CLASSIC (A04) 01.09- | | | | Hatchback (Compact car-C Segment) | | | | |
| 1.4 (L48) (Z 14 XEP) | | Gasolina | FWD | 1364 | 66 | 90 | 01.09-05.14 | ■ |
| 1.6 (L48) (Z 16 XER) | | Gasolina | FWD | 1598 | 85 | 116 | 01.09-05.14 | ■ |
| 1.8 (L48) (Z 18 XER) | | Gasolina | FWD | 1796 | 103 | 140 | 02.13-05.14 | ■ |
| 1.3 CDTI (L48) (Z 13 DTH) | | Diesel | FWD | 1248 | 66 | 90 | 01.09-05.14 | ■ |
| 1.7 CDTI (L48) (A 17 DTJ) | | Diesel | FWD | 1686 | 81 | 110 | 01.09-05.14 | ■ |
| 1.7 CDTI (L48) (Z 17 DTJ) | | Diesel | FWD | 1686 | 81 | 110 | 01.09-05.14 | ■ |
| 1.7 CDTI (L48) (A 17 DTR) | | Diesel | FWD | 1686 | 92 | 125 | 01.09-05.14 | ■ |
| 1.7 CDTI (L48) (Z 17 DTR) | | Diesel | FWD | 1686 | 92 | 125 | 01.09-05.14 | ■ |
| ASTRA H CLASSIC (A04) 01.09-05.14 | | | | Saloon (Compact car-C Segment) | | | | |
| 1.6 (L69) (Z 16 XER) | | Gasolina | FWD | 1598 | 85 | 116 | 01.09-05.14 | ■ |
| 1.8 (L69) (Z 18 XER) | | Gasolina | FWD | 1796 | 103 | 140 | 01.09-09.12 | ■ |
| 1.7 CDTi (L69) (Z 17 DTJ) | | Diesel | FWD | 1686 | 81 | 110 | 01.09-05.14 | ■ |
| 1.7 CDTi (L69) (A 17 DTR) | | Diesel | FWD | 1686 | 92 | 125 | 01.09-05.14 | ■ |
| 1.7 CDTi (L69) (Z 17 DTR) | | Diesel | FWD | 1686 | 92 | 125 | 01.09-05.14 | ■ |
| ASTRA H GTC (A04) 03.05-10.10 | | | | Hatchback (Compact car-C Segment) | | | | |
| 1.2 | -12/09 | Gasolina | FWD | 1199 | 48 | 65 | 10.06- | ■ |
| 1.2 (L08) | -12/09 | Gasolina | FWD | 1229 | 59 | 80 | 08.05-10.10 | ■ |
| 1.4 (L08) (Z 14 XEL) | | Gasolina | FWD | 1364 | 55 | 75 | 03.05-10.10 | ■ |

LISTA DE APLICACIONES - BUYERS GUIDE

| | | | | | | | | | |
|--|---|------------------|-----|------|-----|-----|--|---|--|
| 1.4 (L08) (Z 14 XEP) | -12/09 | Gasolina | FWD | 1364 | 66 | 90 | 03.05-10.10 | ■ | |
| 1.6 CNG | -12/09 | Gasolina | FWD | 1598 | 69 | 94 | 11.05- | ■ | |
| 1.6 (L08) (Z 16 XE1) | -12/09 | Gasolina | FWD | 1598 | 77 | 105 | 03.05-10.10 | ■ | |
| 1.6 (L08) (Z 16 XEP) | -12/09 | Gasolina | FWD | 1598 | 77 | 105 | 03.05-10.10 | ■ | |
| 1.6 (L08) (Z 16 XER) | -12/09 | Gasolina | FWD | 1598 | 85 | 116 | 12.06-10.10 | ■ | |
| 1.6 Turbo (L08) (A 16 LET) | -12/09 | Gasolina | FWD | 1598 | 132 | 180 | 02.07-10.10 | ■ | |
| 1.6 Turbo (L08) (Z 16 LET) | -12/09 | Gasolina | FWD | 1598 | 132 | 180 | 02.07-10.10 | ■ | |
| 1.8 (L08) (Z 18 XE) | -12/09 | Gasolina | FWD | 1796 | 92 | 125 | 03.05-10.10 | ■ | |
| 1.8 (L08) (Z 18 XER) | -12/09 | Gasolina | FWD | 1796 | 103 | 140 | 01.06-10.10 | ■ | |
| 2.0 Turbo (L08) (Z 20 LEL) | -12/09 | Gasolina | FWD | 1998 | 125 | 170 | 03.05-10.10 | ■ | |
| 2.0 Turbo (L08) (Z 20 LER) | -12/09 | Gasolina | FWD | 1998 | 147 | 200 | 03.05-10.10 | ■ | |
| 2.0 Turbo (L08) (Z 20 LEH) | -12/09 | Gasolina | FWD | 1998 | 177 | 240 | 08.05-10.10 | ■ | |
| 1.3 CDTi (L08) (Z 13 DTH) | -12/09 | Diesel | FWD | 1248 | 66 | 90 | 04.05-10.10 | ■ | |
| 1.7 CDTi (L08) (Z 17 DTL) | -12/09 | Diesel | FWD | 1686 | 59 | 80 | 03.05-10.10 | ■ | |
| 1.7 CDTi (L08) (Z 17 DTH) | -12/09 | Diesel | FWD | 1686 | 74 | 101 | 03.05-10.10 | ■ | |
| 1.7 CDTi (L08) (A 17 DTJ) | -12/09 | Diesel | FWD | 1686 | 81 | 110 | 02.07-10.10 | ■ | |
| 1.7 CDTi (L08) (Z 17 DTJ) | -12/09 | Diesel | FWD | 1686 | 81 | 110 | 02.07-10.10 | ■ | |
| 1.7 CDTi (L08) (A 17 DTR) | -12/09 | Diesel | FWD | 1686 | 92 | 125 | 02.07-10.10 | ■ | |
| 1.7 CDTi (L08) (Z 17 DTR) | -12/09 | Diesel | FWD | 1686 | 92 | 125 | 02.07-10.10 | ■ | |
| 1.9 CDTi (L08) (Z 19 DTL) | -12/09 | Diesel | FWD | 1910 | 74 | 101 | 01.06-10.10 | ■ | |
| 1.9 CDTi (L08) (Z 19 DT) | -12/09 | Diesel | FWD | 1910 | 88 | 120 | 09.05-10.10 | ■ | |
| 1.9 CDTi 16V (L08) (Z 19 DTJ) | -12/09 | Diesel | FWD | 1910 | 88 | 120 | 03.05-10.10 | ■ | |
| 1.9 CDTi (L08) (Z 19 DTH) | -12/09 | Diesel | FWD | 1910 | 110 | 150 | 03.05-10.10 | ■ | |
| ASTRA H TwinTop (A04) 09.05-12.13 | | | | | | | Convertible (Compact car-C Segment) | | |
| 1.4 (L67) (Z 14 XEP) | | Gasolina | FWD | 1364 | 66 | 90 | 10.05-10.10 | ■ | |
| 1.6 (L67) (Z 16 XE1) | -12/09 | Gasolina | FWD | 1598 | 77 | 105 | 09.05-10.10 | ■ | |
| 1.6 (L67) (Z 16 XEP) | -12/09 | Gasolina | FWD | 1598 | 77 | 105 | 09.05-10.10 | ■ | |
| 1.6 (L67) (Z 16 XER) | -12/09 | Gasolina | FWD | 1598 | 85 | 116 | 12.06-10.10 | ■ | |
| 1.6 Turbo (L67) (A 16 LET) | -12/09 | Gasolina | FWD | 1598 | 132 | 180 | 02.07-10.10 | ■ | |
| 1.6 Turbo (L67) (Z 16 LET) | -12/09 | Gasolina | FWD | 1598 | 132 | 180 | 02.07-10.10 | ■ | |
| 1.8 (L67) (Z 18 XE) | -12/09 | Gasolina | FWD | 1796 | 92 | 125 | 09.05-10.10 | ■ | |
| 1.8 (L67) (A 18 XER) | -12/09 | Gasolina | FWD | 1796 | 103 | 140 | 09.05-10.10 | ■ | |
| 1.8 (L67) (Z 18 XER) | -12/09 | Gasolina | FWD | 1796 | 103 | 140 | 09.05-10.10 | ■ | |
| 2.0 Turbo (L67) (Z 20 LEL) | -12/09 | Gasolina | FWD | 1998 | 125 | 170 | 09.05-10.10 | ■ | |
| 2.0 Turbo (L67) (Z 20 LER) | -12/09 | Gasolina | FWD | 1998 | 147 | 200 | 09.05-10.10 | ■ | |
| 1.9 CDTi (L67) (Z 19 DTH) | -12/09 | Diesel | FWD | 1910 | 110 | 150 | 09.05-10.10 | ■ | |
| COMBO C 10.01- | | | | | | | Box Body/MPV (LCVs-N1 Segment) | | |
| 1.4 16V (Z 14 XEP) | discØ 280, increased payload, drum brak.rear axle | Gasolina | FWD | 1364 | 66 | 90 | 08.05- | ■ | |
| 1.6 (Z 16 SE) | increased payload, discØ 280, disc brak.rear axle | Gasolina | FWD | 1598 | 64 | 87 | 10.01- | ■ | |
| 1.6 CNG 16V (Z 16 YNG) | discØ 280 | Gasol./Gas (CNG) | FWD | 1598 | 69 | 94 | 06.06- | ■ | |
| 1.6 CNG 16V (Z 16 YNG) | discØ 280 | Gasol./Gas (CNG) | FWD | 1598 | 71 | 97 | 04.05- | ■ | |
| 1.3 CDTi 16V (Z 13 DT) | discØ 280, increased payload | Diesel | FWD | 1248 | 51 | 69 | 08.05- | ■ | |
| 1.3 CDTi 16V (Z 13 DTJ) | discØ 280, increased payload | Diesel | FWD | 1248 | 55 | 75 | 10.05-12.12 | ■ | |
| 1.7 DI 16V (Y 17 DTL) | increased payload, discØ 280, disc brak.rear axle | Diesel | FWD | 1686 | 48 | 65 | 10.01- | ■ | |
| 1.7 DTi 16V (Y 17 DT) | increased payload, discØ 280, disc brak.rear axle | Diesel | FWD | 1686 | 55 | 75 | 10.01- | ■ | |
| 1.7 CDTi 16V (Z 17 DTH) | discØ 280 | Diesel | FWD | 1686 | 74 | 101 | 12.04- | ■ | |

LISTA DE APLICACIONES - BUYERS GUIDE

| COMBO C Tour 10.01- | | | | | | MPV (Large MPV-M1 Segment) | | | |
|---|--|------------------|-----|------|-----|--|-------------|---|--|
| 1.4 (Z 14 XEP) | discØ 280, increased payload, disc brak.rear axle, drum brak.rear axle | Gasolina | FWD | 1364 | 66 | 90 | 10.04-12.11 | ■ | |
| 1.6 | increased payload | Gasolina | FWD | 1598 | 62 | 84 | 10.01-09.06 | ■ | |
| 1.6 (Z 16 SE) | discØ 280, increased payload, disc brak.rear axle, drum brak.rear axle | Gasolina | FWD | 1598 | 64 | 87 | 10.01-09.06 | ■ | |
| 1.6 CNG (Z 16 YNG) | discØ 280 | Gasol./Gas (CNG) | FWD | 1598 | 69 | 94 | 06.06-12.11 | ■ | |
| 1.6 CNG (Z 16 YNG) | discØ 280 | Gasol./Gas (CNG) | FWD | 1598 | 71 | 97 | 04.05-01.11 | ■ | |
| 1.3 CDTI 16V (Y 13 DT) | discØ 280, increased payload, disc brak.rear axle, drum brak.rear axle | Diesel | FWD | 1248 | 51 | 69 | 06.04-01.11 | ■ | |
| 1.3 CDTI 16V (Z 13 DT) | discØ 280, increased payload, disc brak.rear axle, drum brak.rear axle | Diesel | FWD | 1248 | 51 | 69 | 06.04-01.11 | ■ | |
| 1.3 CDTI 16V (Z 13 DTJ) | discØ 280, increased payload | Diesel | FWD | 1248 | 55 | 75 | 10.05-12.11 | ■ | |
| 1.7 DI 16V (Y 17 DTL) | increased payload, discØ 280, disc brak.rear axle | Diesel | FWD | 1686 | 48 | 65 | 10.01-06.04 | ■ | |
| 1.7 DTI 16V (Y 17 DT) | increased payload, discØ 280, disc brak.rear axle | Diesel | FWD | 1686 | 55 | 75 | 10.01-06.04 | ■ | |
| 1.7 CDTI 16V (Z 17 DTH) | discØ 280 | Diesel | FWD | 1686 | 74 | 101 | 07.04-12.11 | ■ | |
| CORSA C (X01) 09.00- | | | | | | Hatchback Van (LCVs-N1 Segment) | | | |
| 1.7 CDTi (F08, W5L) (Z 17 DTH) | -12/06, discØ 280 | Diesel | FWD | 1686 | 74 | 101 | 08.03-12.12 | ■ | |
| CORSA C (X01) 09.00-12.09 | | | | | | Saloon (Supermini car-B Segment) | | | |
| 1.6 (Z 16 SE) | increased payload | Gasolina | FWD | 1598 | 69 | 94 | 01.03-12.07 | ■ | |
| 1.7 CDTi (Z 17 DTH) | | Diesel | FWD | 1686 | 74 | 100 | 01.05-12.08 | ■ | |
| CORSA C / VITA C (X01) 09.00-12.09 | | | | | | Hatchback (Supermini car-B Segment) | | | |
| 1.6 (F08, F68) | increased payload | Gasolina | FWD | 1598 | 62 | 84 | 09.00-12.09 | ■ | |
| 1.7 CDTi (F08, F68) (Z 17 DTH) | -12/06, discØ 280 | Diesel | FWD | 1686 | 74 | 100 | 06.03-12.09 | ■ | |
| CORSA D (S07) 07.06- | | | | | | Hatchback Van (LCVs-N1 Segment) | | | |
| 1.6 (L08) (Z 16 LER) | discØ 308 | Gasolina | FWD | 1598 | 141 | 192 | 07.12-08.14 | ■ | |
| CORSA D (S07) 07.06- | | | | | | Hatchback (Supermini car-B Segment) | | | |
| 1.6 Turbo (L08, L68) (A 16 LEL) | discØ 308 | Gasolina | FWD | 1598 | 110 | 150 | 05.07-08.14 | ■ | |
| 1.6 Turbo (L08, L68) (Z 16 LEL) | discØ 308 | Gasolina | FWD | 1598 | 110 | 150 | 05.07-08.14 | ■ | |
| 1.6 T | | Gasolina | FWD | 1598 | 132 | 180 | 02.07- | ■ | |
| 1.6 Turbo (L08, L68) (A 16 LER) | discØ 308 | Gasolina | FWD | 1598 | 141 | 192 | 11.06-08.14 | ■ | |
| 1.6 Turbo (L08, L68) (B 16 LER) | discØ 308 | Gasolina | FWD | 1598 | 141 | 192 | 11.06-08.14 | ■ | |
| 1.6 Turbo (L08, L68) (Z 16 LER) | discØ 308 | Gasolina | FWD | 1598 | 141 | 192 | 11.06-08.14 | ■ | |
| 1.6 Turbo (L08, L68) (A 16 LES) | | Gasolina | FWD | 1598 | 155 | 211 | 06.11-08.14 | ■ | |
| CORSA E (X15) 09.14- | | | | | | Hatchback Van (LCVs-N1 Segment) | | | |
| 1.2 (08) (B 12 XEL) | Rim 16 | Gasolina | FWD | 1229 | 51 | 69 | 01.15- | ■ | |
| 1.4 (08) (B 14 XEJ) | Rim 16 | Gasolina | FWD | 1398 | 55 | 75 | 09.14- | ■ | |
| 1.4 (08) (B 14 XEL) | Rim 16 | Gasolina | FWD | 1398 | 66 | 90 | 09.14- | ■ | |
| 1.3 CDTI (08) (B 13 DTC) | Rim 16 | Diesel | FWD | 1248 | 55 | 75 | 01.15- | ■ | |
| 1.3 CDTI (08) (B 13 DTN) | Rim 16 | Diesel | FWD | 1248 | 55 | 75 | 01.15- | ■ | |
| 1.3 CDTI (08) (B 13 DTE) | Rim 16 | Diesel | FWD | 1248 | 70 | 95 | 09.14- | ■ | |
| 1.3 CDTI (08) (B 13 DTR) | Rim 16 | Diesel | FWD | 1248 | 70 | 95 | 09.14- | ■ | |
| CORSA E (X15) 09.14- | | | | | | Hatchback (Supermini car-B Segment) | | | |
| 1.0 (08, 68) (B 10 XFL) | Rim 16 | Gasolina | FWD | 999 | 66 | 90 | 09.14- | ■ | |
| 1.0 (08, 68) (D 10 XFL) | Rim 16 | Gasolina | FWD | 999 | 66 | 90 | 09.14- | ■ | |

LISTA DE APLICACIONES - BUYERS GUIDE

| | | | | | | | | |
|---------------------------------------|----------------------------|-------------------|-----|----------------------------------|-----|-----|-------------|---|
| 1.0 (08, 68) (F 10 XFL) | Rim 16 | Gasolina | FWD | 999 | 66 | 90 | 09.14- | ■ |
| 1.0 (08, 68) (B 10 XFT) | Rim 16 | Gasolina | FWD | 999 | 85 | 115 | 09.14- | ■ |
| 1.0 (08, 68) (D 10 XFT) | Rim 16 | Gasolina | FWD | 999 | 85 | 115 | 09.14- | ■ |
| 1.2 (08, 68) (B 12 XEL) | Rim 16 | Gasolina | FWD | 1229 | 51 | 69 | 09.14- | ■ |
| 1.4 Turbo (08, 68) (B 14 NEJ) | Rim 16 | Gasolina | FWD | 1364 | 74 | 101 | 09.14-06.19 | ■ |
| 1.4 Turbo (08, 68) (D 14 NEJ) | Rim 16 | Gasolina | FWD | 1364 | 74 | 101 | 09.14-06.19 | ■ |
| 1.4 Turbo (08, 68) (B 14 NEH) | Rim 16, POC J79, discØ 308 | Gasolina | FWD | 1364 | 110 | 150 | 03.15- | ■ |
| 1.4 Turbo (08, 68) (D 14 NEH) | Rim 16, POC J79, discØ 308 | Gasolina | FWD | 1364 | 110 | 150 | 03.15- | ■ |
| 1.4 (08, 68) (B 14 XEJ) | Rim 16 | Gasolina | FWD | 1398 | 55 | 75 | 09.14- | ■ |
| 1.4 (08, 68) (B 14 XEL) | Rim 16 | Gasolina | FWD | 1398 | 66 | 90 | 09.14- | ■ |
| 1.4 (08, 68) (D 14 XEL) | Rim 16 | Gasolina | FWD | 1398 | 66 | 90 | 09.14- | ■ |
| 1.6 Turbo (08, 68) (B 16 LER) | Rim 16, POC J79, discØ 308 | Gasolina | FWD | 1598 | 152 | 207 | 03.15- | ■ |
| 1.6 Turbo (08, 68) (B 16 LES) | Rim 16, POC J79, discØ 308 | Gasolina | FWD | 1598 | 152 | 207 | 03.15- | ■ |
| 1.4 LPG (08, 68) (B 14 XEL) | Rim 16 | Gasol./G as (LPG) | FWD | 1398 | 64 | 87 | 11.15- | ■ |
| 1.4 LPG (08, 68) (B 14 XEL) | Rim 16 | Gasol./G as (LPG) | FWD | 1398 | 66 | 90 | 03.15- | ■ |
| 1.3 CDTI (08, 68) (B 13 DTC) | Rim 16 | Diesel | FWD | 1248 | 55 | 75 | 09.14- | ■ |
| 1.3 CDTI (08, 68) (B 13 DTN) | Rim 16 | Diesel | FWD | 1248 | 55 | 75 | 09.14- | ■ |
| 1.3 CDTI (08, 68) (B 13 DTE) | Rim 16 | Diesel | FWD | 1248 | 70 | 95 | 09.14- | ■ |
| 1.3 CDTI (08, 68) (B 13 DTR) | Rim 16 | Diesel | FWD | 1248 | 70 | 95 | 09.14- | ■ |
| MERIVA A (X03) 05.03-05.10 | | | | MPV (Mini MPV-M1 Segment) | | | | |
| 1.4 16V Twinport (E75) (Z 14 XEP) | -12/08, discØ 280, RimHo 5 | Gasolina | FWD | 1364 | 66 | 90 | 07.04-05.10 | ■ |
| 1.6 (E75) (Z 16 SE) | RimHo 5 | Gasolina | FWD | 1598 | 64 | 87 | 05.03-05.10 | ■ |
| 1.6 16V (E75) (Z 16 XE) | discØ 280 | Gasolina | FWD | 1598 | 74 | 100 | 05.03-01.06 | ■ |
| 1.6 (E75) (Z 16 XEP) | -12/08, discØ 280 | Gasolina | FWD | 1598 | 77 | 105 | 01.06-05.10 | ■ |
| 1.6 Turbo (E75) (Z 16 LET) | -12/08 | Gasolina | FWD | 1598 | 132 | 180 | 09.05-05.10 | ■ |
| 1.8 (E75) (Z 18 XE) | -12/08, discØ 280 | Gasolina | FWD | 1796 | 92 | 125 | 05.03-05.10 | ■ |
| 1.4 16V Twinport LPG (E75) (Z 14 XEP) | discØ 280, RimHo 5 | Gasol./G as (LPG) | FWD | 1364 | 66 | 90 | 07.04-05.10 | ■ |
| 1.3 CDTI (E75) (Y 13 DT) | -12/08, discØ 280 | Diesel | FWD | 1248 | 51 | 69 | 04.05-05.10 | ■ |
| 1.3 CDTI (E75) (Z 13 DT) | -12/08, discØ 280 | Diesel | FWD | 1248 | 51 | 69 | 04.05-05.10 | ■ |
| 1.3 CDTI (E75) (Z 13 DTJ) | 01/06-, discØ 280 | Diesel | FWD | 1248 | 55 | 75 | 09.03-05.10 | ■ |
| 1.7 DTI (E75) (Y 17 DT) | -12/08, discØ 280 | Diesel | FWD | 1686 | 55 | 75 | 09.03-05.10 | ■ |
| 1.7 CDTI (E75) (Z 17 DT) | -12/08, discØ 280 | Diesel | FWD | 1686 | 74 | 100 | 09.03-05.10 | ■ |
| 1.7 CDTI (E75) (Z 17 DTH) | -12/08, discØ 280 | Diesel | FWD | 1686 | 74 | 100 | 09.03-05.10 | ■ |
| 1.7 CDTI (E75) (Z 17 DTR) | -12/08, discØ 280 | Diesel | FWD | 1686 | 92 | 125 | 09.06-05.10 | ■ |
| MERIVA B (S10) 06.10- | | | | MPV (Mini MPV-M1 Segment) | | | | |
| 1.4 (75) (A 14 NEL) | | Gasolina | FWD | 1364 | 88 | 120 | 06.10-03.17 | ■ |
| 1.4 (75) (B 14 NEL) | | Gasolina | FWD | 1364 | 88 | 120 | 06.10-03.17 | ■ |
| 1.4 (75) (A 14 NET) | | Gasolina | FWD | 1364 | 103 | 140 | 06.10-03.17 | ■ |
| 1.4 (75) (B 14 NET) | | Gasolina | FWD | 1364 | 103 | 140 | 06.10-03.17 | ■ |
| 1.4 (75) (A 14 XER) | | Gasolina | FWD | 1398 | 74 | 100 | 06.10-03.17 | ■ |
| 1.4 (75) (B 14 XER) | | Gasolina | FWD | 1398 | 74 | 100 | 06.10-03.17 | ■ |
| 1.4 LPG (75) (A 14 NEL) | discØ 280, discØ 308 | Gasol./G as (LPG) | FWD | 1364 | 88 | 120 | 06.11-03.17 | ■ |
| 1.4 LPG (75) (B 14 NEL) | discØ 280, discØ 308 | Gasol./G as (LPG) | FWD | 1364 | 88 | 120 | 06.11-03.17 | ■ |
| 1.3 CDTI (75) (A 13 DTC) | | Diesel | FWD | 1248 | 55 | 75 | 06.10-10.13 | ■ |
| 1.3 CDTI (75) (A 13 DTE) | | Diesel | FWD | 1248 | 70 | 95 | 06.10-11.14 | ■ |
| 1.6 CDTi (75) (B 16 DTC) | | Diesel | FWD | 1598 | 70 | 95 | 01.14-01.17 | ■ |
| 1.6 CDTi (75) (B 16 DTE) | | Diesel | FWD | 1598 | 81 | 110 | 03.14-03.17 | ■ |
| 1.6 CDTi (75) (B 16 DTL) | | Diesel | FWD | 1598 | 81 | 110 | 03.14-03.17 | ■ |

LISTA DE APLICACIONES - BUYERS GUIDE

| | | | | | | | | | |
|---------------------------------------|--|------------------|-----|------|-----|-----|---|---|--|
| 1.6 CDTi (75) (B 16 DTN) | | Diesel | FWD | 1598 | 81 | 110 | 03.14-03.17 | ■ | |
| 1.6 CDTi (75) (B 16 DTH) | | Diesel | FWD | 1598 | 100 | 136 | 08.13-01.17 | ■ | |
| 1.7 CDTi (75) (A 17 DT) | discØ 280, discØ 308 | Diesel | FWD | 1686 | 74 | 100 | 06.10-01.17 | ■ | |
| 1.7 CDTi (75) (A 17 DTC) | discØ 280, discØ 308 | Diesel | FWD | 1686 | 81 | 110 | 06.10-06.15 | ■ | |
| 1.7 CDTi (75) (A 17 DTI) | discØ 280, discØ 308 | Diesel | FWD | 1686 | 81 | 110 | 06.10-06.15 | ■ | |
| 1.7 CDTi (75) (A 17 DTS) | discØ 280, discØ 308 | Diesel | FWD | 1686 | 96 | 131 | 06.10-10.13 | ■ | |
| MERIVA B VAN (S10) 06.10-03.17 | | | | | | | Box Body/MPV (Mini MPV-M1 Segment) | | |
| 1.4 ECOTEC (75) | | Gasolina | FWD | 1398 | 74 | 101 | 01.13-03.17 | ■ | |
| 1.3 CDTi (75) | | Diesel | FWD | 1248 | 70 | 95 | 01.13-11.14 | ■ | |
| 1.6 CDTi (75) | | Diesel | FWD | 1598 | 70 | 95 | 01.14-01.17 | ■ | |
| 1.6 CDTi (75) | | Diesel | FWD | 1598 | 81 | 110 | 03.14-03.17 | ■ | |
| 1.7 CDTi (75) | discØ 280, discØ 308 | Diesel | FWD | 1686 | 74 | 101 | 01.13-01.17 | ■ | |
| 1.7 CDTi (75) | discØ 280, discØ 308 | Diesel | FWD | 1686 | 81 | 110 | 01.13-10.13 | ■ | |
| 1.7 CDTi (75) | discØ 280, discØ 308 | Diesel | FWD | 1686 | 96 | 131 | 01.13-10.13 | ■ | |
| ZAFIRA A (T98) 04.99-06.06 | | | | | | | MPV (Compact MPV-M1 Segment) | | |
| 1.6 16V (F75) (X 16 XEL) | | Gasolina | FWD | 1598 | 74 | 101 | 04.99-06.05 | ■ | |
| 1.6 16V (F75) (Z 16 XE) | | Gasolina | FWD | 1598 | 74 | 101 | 04.99-06.05 | ■ | |
| 1.6 (F75) (Z 16 XE) | | Gasolina | FWD | 1598 | 76 | 103 | 10.03-06.05 | ■ | |
| 1.8 16V (F75) (X 18 XE1) | | Gasolina | FWD | 1796 | 85 | 116 | 04.99-09.00 | ■ | |
| 1.8 16V (F75) (Z 18 XE) | | Gasolina | FWD | 1796 | 92 | 125 | 09.00-06.05 | ■ | |
| 2.0 OPC (F75) (Z 20 LET) | | Gasolina | FWD | 1998 | 147 | 200 | 11.02-06.05 | ■ | |
| 2.2 16V (F75) (Z 22 SE) | | Gasolina | FWD | 2198 | 108 | 147 | 09.00-06.05 | ■ | |
| 1.6 LPG (F75) (X 16 XEL) | | Gasol./Gas (LPG) | FWD | 1598 | 74 | 101 | 04.99-06.05 | ■ | |
| 1.6 LPG (F75) (Z 16 XE) | | Gasol./Gas (LPG) | FWD | 1598 | 74 | 101 | 04.99-06.05 | ■ | |
| 1.6 LPG (F75) (Z 16 XEP) | | Gasol./Gas (LPG) | FWD | 1598 | 76 | 103 | 10.03-06.05 | ■ | |
| 1.6 CNG (F75) (Z 16 YNG) | | Gasol./Gas (CNG) | FWD | 1598 | 71 | 97 | 09.01-06.05 | ■ | |
| 2.0 DI 16V (F75) (X 20 DTL) | | Diesel | FWD | 1995 | 60 | 82 | 07.99-06.05 | ■ | |
| 2.0 DI 16V (F75) (Y 20 DTL) | | Diesel | FWD | 1995 | 60 | 82 | 07.99-06.05 | ■ | |
| 2.0 DTI 16V (F75) (Y 20 DTH) | | Diesel | FWD | 1995 | 74 | 101 | 09.00-06.05 | ■ | |
| 2.2 DTI 16V (F75) (Y 22 DTR) | | Diesel | FWD | 2172 | 86 | 117 | 01.02-06.05 | ■ | |
| 2.2 DTI 16V (F75) (Y 22 DTR) | | Diesel | FWD | 2172 | 92 | 125 | 01.02-06.05 | ■ | |
| ZAFIRA B (A05) 07.05- | | | | | | | Box Body/MPV (LCVs-N1 Segment) | | |
| 1.8 VAN (M75) (A 18 XER) | -12/11 | Gasolina | FWD | 1796 | 103 | 140 | 07.05-04.15 | ■ | |
| 1.8 VAN (M75) (Z 18 XER) | -12/11 | Gasolina | FWD | 1796 | 103 | 140 | 07.05-04.15 | ■ | |
| 2.0 VAN (M75) (Z 20 LER) | not police vehicles, for police vehicles | Gasolina | FWD | 1998 | 147 | 200 | 07.05-12.10 | ■ | |
| 2.2 DGi VAN (M75) (Z 22 YH) | not police vehicles, for police vehicles | Gasolina | FWD | 2198 | 110 | 150 | 07.05-12.11 | ■ | |
| 1.6 CNG VAN (M75) (Z 16 YNG) | not police vehicles, for police vehicles | Gasol./Gas (CNG) | FWD | 1598 | 69 | 94 | 07.05-04.15 | ■ | |
| 1.6 CNG Turbo VAN (M75) (A 16 XNT) | -12/11 | Gasol./Gas (CNG) | FWD | 1598 | 110 | 150 | 02.09-04.15 | ■ | |
| 1.6 CNG Turbo VAN (M75) (Z 16 XNT) | -12/11 | Gasol./Gas (CNG) | FWD | 1598 | 110 | 150 | 02.09-04.15 | ■ | |
| 1.7 CDTi VAN (M75) (A 17 DTJ) | -12/11, not police vehicles, for police vehicles | Diesel | FWD | 1686 | 81 | 110 | 01.08-04.15 | ■ | |
| 1.7 CDTi VAN (M75) (Z 17 DTJ) | -12/11, not police vehicles, for police vehicles | Diesel | FWD | 1686 | 81 | 110 | 01.08-04.15 | ■ | |
| 1.7 CDTi VAN (M75) (A 17 DTR) | | Diesel | FWD | 1686 | 92 | 125 | 01.08-04.15 | ■ | |

LISTA DE APLICACIONES - BUYERS GUIDE

| | | | | | | | | |
|--|--|------------------|-----|--|-----|-----|-------------|---|
| 1.9 CDTI VAN (M75) (Z 19 DT) | not police vehicles, for police vehicles | Diesel | FWD | 1910 | 88 | 120 | 07.05-04.15 | ■ |
| 1.9 CDTI VAN (M75) (Z 19 DTH) | not police vehicles, for police vehicles | Diesel | FWD | 1910 | 110 | 150 | 07.05-04.15 | ■ |
| ZAFIRA / ZAFIRA FAMILY B (A05) 07.05- | | | | MPV (Compact MPV-M1 Segment) | | | | |
| 1.6 (M75) (Z 16 XE1) | -12/11 | Gasolina | FWD | 1598 | 77 | 105 | 07.05-09.12 | ■ |
| 1.6 (M75) (Z 16 XEP) | -12/11 | Gasolina | FWD | 1598 | 77 | 105 | 07.05-09.12 | ■ |
| 1.6 (M75) (A 16 XER) | -12/11 | Gasolina | FWD | 1598 | 85 | 115 | 01.08-04.15 | ■ |
| 1.6 (M75) (Z 16 XER) | -12/11 | Gasolina | FWD | 1598 | 85 | 115 | 01.08-04.15 | ■ |
| 1.8 (M75) (A 18 XEL) | discØ 280 discØ 308 | Gasolina | FWD | 1796 | 88 | 120 | 06.13-04.15 | ■ |
| 1.8 (M75) (A 18 XER) | -12/11 | Gasolina | FWD | 1796 | 103 | 140 | 07.05-04.15 | ■ |
| 1.8 (M75) (Z 18 XER) | -12/11 | Gasolina | FWD | 1796 | 103 | 140 | 07.05-04.15 | ■ |
| 2.0 (M75) (Z 20 LER) | not police vehicles, for police vehicles | Gasolina | FWD | 1998 | 147 | 200 | 07.05-12.10 | ■ |
| 2.0 (M75) (Z 20 LEH) | | Gasolina | FWD | 1998 | 177 | 241 | 01.06-12.10 | ■ |
| 2.2 (M75) (Z 22 YH) | -12/11, not police vehicles, for police vehicles | Gasolina | FWD | 2198 | 110 | 150 | 07.05-12.12 | ■ |
| 1.8 LPG (M75) (Z 18 XER) | | Gasol./Gas (LPG) | FWD | 1796 | 103 | 140 | 07.09-04.15 | ■ |
| 1.6 CNG (M75) (Z 16 YNG) | -12/11, not police vehicles, for police vehicles | Gasol./Gas (CNG) | FWD | 1598 | 69 | 94 | 07.05-04.15 | ■ |
| 1.6 CNG Turbo (M75) (A 16 XNT) | -12/11 | Gasol./Gas (CNG) | FWD | 1598 | 110 | 150 | 04.10-04.15 | ■ |
| 1.6 CNG Turbo (M75) (Z 16 XNT) | -12/11 | Gasol./Gas (CNG) | FWD | 1598 | 110 | 150 | 04.10-04.15 | ■ |
| 1.6 FlexFuel (M75) (Z 16 XER) | | Gasol./Etanol | FWD | 1598 | 85 | 116 | 08.08-12.12 | ■ |
| 1.7 CDTI (M75) (A 17 DTJ) | -12/11, not police vehicles, for police vehicles | Diesel | FWD | 1686 | 81 | 110 | 01.08-04.15 | ■ |
| 1.7 CDTI (M75) (Z 17 DTJ) | -12/11, not police vehicles, for police vehicles | Diesel | FWD | 1686 | 81 | 110 | 01.08-04.15 | ■ |
| 1.7 CDTI (M75) (A 17 DTR) | -12/11, discØ 280, not police vehicles, for ambulances, driving school car, for police vehicles, for taxis | Diesel | FWD | 1686 | 92 | 125 | 03.07-04.15 | ■ |
| 1.9 CDTI (M75) (Z 19 DTL) | not police vehicles, for police vehicles | Diesel | FWD | 1910 | 74 | 100 | 07.05-12.10 | ■ |
| 1.9 CDTI (M75) (Z 19 DT) | for police vehicles, not police vehicles | Diesel | FWD | 1910 | 88 | 120 | 07.05-04.15 | ■ |
| 1.9 CDTI (M75) (Z 19 DTH) | -12/11, not police vehicles, for police vehicles | Diesel | FWD | 1910 | 110 | 150 | 07.05-04.15 | ■ |
| SATURN | | | | | | | | |
| ASTRA (U.S.A.) 09.03-12.09 | | | | Hatchback (Compact car-C Segment) | | | | |
| All models | 01/08- | Gasolina | FWD | | | | 09.03- | ■ |
| 1.8 (2H0) | | Gasolina | FWD | 1796 | 104 | 141 | 09.07-12.09 | ■ |
| SUBARU | | | | | | | | |
| TRAVIQ 08.00-08.05 | | | | MPV (Compact MPV-M1 Segment) | | | | |
| 2.2 | | Gasolina | FWD | 2198 | 108 | 147 | 08.00-08.05 | ■ |
| VAUXHALL | | | | | | | | |
| ADAM (M13) 10.12- | | | | Hatchback (City car-A Segment) | | | | |
| 1.0 | Rim 16, discØ 308 | Gasolina | FWD | 998 | 66 | 90 | 07.14- | ■ |
| 1.0 (B 10 XFT) | Rim 16, discØ 308 | Gasolina | FWD | 999 | 85 | 116 | 07.14-11.18 | ■ |
| 1.0 (D 10 XFT) | Rim 16, discØ 308 | Gasolina | FWD | 999 | 85 | 116 | 07.14-11.18 | ■ |
| 1.2 (A 12 XEL) | Rim 16, discØ 308 | Gasolina | FWD | 1229 | 51 | 69 | 10.12-04.19 | ■ |
| 1.2 (B 12 XEL) | Rim 16, discØ 308 | Gasolina | FWD | 1229 | 51 | 69 | 10.12-04.19 | ■ |
| 1.4 S (B 14 NEH) | Rim 16, discØ 308 | Gasolina | FWD | 1364 | 110 | 150 | 11.14-01.19 | ■ |
| 1.4 (A 14 XEL) | Rim 16, discØ 308 | Gasolina | FWD | 1398 | 64 | 87 | 10.12-02.19 | ■ |

LISTA DE APLICACIONES - BUYERS GUIDE

| | | | | | | | | | |
|--|-------------------|------------------|-----|------|-----|-----|--|---|--|
| 1.4 (B 14 XEL) | Rim 16, discØ 308 | Gasolina | FWD | 1398 | 64 | 87 | 10.12-02.19 | ■ | |
| 1.4 (A 14 XER) | Rim 16, discØ 308 | Gasolina | FWD | 1398 | 74 | 101 | 10.12-02.19 | ■ | |
| 1.4 (B 14 XER) | Rim 16, discØ 308 | Gasolina | FWD | 1398 | 74 | 101 | 10.12-02.19 | ■ | |
| 1.4 LPG | Rim 16, discØ 308 | Gasol./Gas (LPG) | FWD | 1398 | 64 | 87 | 07.13- | ■ | |
| ASTRA Mk IV (G) (T98) 03.01-10.05 | | | | | | | Convertible (Compact car-C Segment) | | |
| 1.8 16V (Z 18 XE) | | Gasolina | FWD | 1796 | 92 | 125 | 03.01-10.05 | ■ | |
| 2.0 (Z 20 LET) | | Gasolina | FWD | 1998 | 147 | 200 | 09.02-10.05 | ■ | |
| 2.2 16V (Z 22 SE) | | Gasolina | FWD | 2198 | 108 | 147 | 03.01-10.05 | ■ | |
| ASTRA Mk IV (G) (T98) 03.00-08.05 | | | | | | | Coupe (Compact car-C Segment) | | |
| 1.6 16V (Z 16 XEP) | | Gasolina | FWD | 1598 | 76 | 103 | 03.00-08.05 | ■ | |
| 1.8 16V (X 18 XE1) | | Gasolina | FWD | 1796 | 85 | 115 | 03.00-08.05 | ■ | |
| 1.8 16V (Z 18 XE) | | Gasolina | FWD | 1796 | 92 | 125 | 09.00-08.05 | ■ | |
| 2.0 16V Turbo (Z 20 LET) | | Gasolina | FWD | 1998 | 140 | 190 | 09.00-08.05 | ■ | |
| 2.2 16V (Z 22 SE) | | Gasolina | FWD | 2198 | 108 | 147 | 03.00-08.05 | ■ | |
| 1.8 16V Dualfuel (Z 18 XE) | | Gasol./Gas (LPG) | FWD | 1796 | 87 | 118 | 09.02-08.05 | ■ | |
| 1.8 16V Dualfuel (Z 18 XE) | vehicles with ABS | Gasol./Gas (LPG) | FWD | 1796 | 92 | 125 | 07.02-08.04 | ■ | |
| ASTRA Mk IV (G) (T98) 02.98-05.05 | | | | | | | Estate (Compact car-C Segment) | | |
| 1.8 16V (X 18 XE1) | vehicles with ABS | Gasolina | FWD | 1796 | 85 | 116 | 02.98-08.00 | ■ | |
| 1.8 16V (Z 18 XE) | vehicles with ABS | Gasolina | FWD | 1796 | 92 | 125 | 09.00-05.05 | ■ | |
| 2.2 16V (Z 22 SE) | | Gasolina | FWD | 2198 | 108 | 147 | 03.01-05.05 | ■ | |
| 1.8 16V Dualfuel (Z 18 XE) | | Gasol./Gas (LPG) | FWD | 1796 | 87 | 118 | 09.02-05.05 | ■ | |
| 1.8 16V Dualfuel (Z 18 XE) | vehicles with ABS | Gasol./Gas (LPG) | FWD | 1796 | 92 | 125 | 07.02-12.03 | ■ | |
| 2.0 DI (X 20 DTL) | | Diesel | FWD | 1995 | 60 | 82 | 03.98-04.04 | ■ | |
| 2.0 DI (Y 20 DTL) | | Diesel | FWD | 1995 | 60 | 82 | 03.98-04.04 | ■ | |
| 2.0 DTI 16V (Y 20 DTH) | vehicles with ABS | Diesel | FWD | 1995 | 74 | 101 | 03.98-04.04 | ■ | |
| ASTRA Mk IV (G) (T98) 02.98-05.05 | | | | | | | Hatchback (Compact car-C Segment) | | |
| 1.8 16V (F08, F48) (X 18 XE1) | vehicles with ABS | Gasolina | FWD | 1796 | 85 | 116 | 02.98-09.00 | ■ | |
| 1.8 16V (F08, F48) (Z 18 XE) | vehicles with ABS | Gasolina | FWD | 1796 | 92 | 125 | 09.00-05.05 | ■ | |
| 2.0 16V (F08) (X 20 XEV) | | Gasolina | FWD | 1998 | 100 | 136 | 02.98-05.05 | ■ | |
| 2.0 SRI Turbo (F08) (Z 20 LET) | | Gasolina | FWD | 1998 | 141 | 192 | 11.01-05.05 | ■ | |
| 2.0 (F08) (Z 20 LET) | | Gasolina | FWD | 1998 | 147 | 199 | 08.02-05.05 | ■ | |
| 2.2 16V (F08, F48) (Z 22 SE) | | Gasolina | FWD | 2198 | 108 | 147 | 03.01-05.05 | ■ | |
| 1.8 16V Dualfuel (F08, F48) (Z 18 XE) | vehicles with ABS | Gasol./Gas (LPG) | FWD | 1796 | 87 | 118 | 09.02-05.05 | ■ | |
| 1.8 16V Dualfuel (F08, F48) (Z 18 XE) | vehicles with ABS | Gasol./Gas (LPG) | FWD | 1796 | 92 | 125 | 07.02-12.03 | ■ | |
| 2.0 DI (F48) (X 20 DTL) | | Diesel | FWD | 1995 | 60 | 82 | 02.98-05.05 | ■ | |
| 2.0 DI (F48) (Y 20 DTL) | | Diesel | FWD | 1995 | 60 | 82 | 02.98-05.05 | ■ | |
| 2.0 DTI 16V (F48) (Y 20 DTH) | vehicles with ABS | Diesel | FWD | 1995 | 74 | 101 | 08.99-05.05 | ■ | |
| ASTRA Mk IV (G) (T98) 02.98-05.05 | | | | | | | Saloon (Compact car-C Segment) | | |
| 1.4 16V (X 14 XE) | | Gasolina | FWD | 1389 | 66 | 90 | 09.98-05.05 | ■ | |
| 1.4 16V (Z 14 XE) | | Gasolina | FWD | 1389 | 66 | 90 | 09.98-05.05 | ■ | |
| 1.8 16V (X 18 XE1) | vehicles with ABS | Gasolina | FWD | 1796 | 85 | 116 | 02.98-07.04 | ■ | |
| 1.8 16V (Z 18 XE) | vehicles with ABS | Gasolina | FWD | 1796 | 92 | 125 | 02.98-07.04 | ■ | |
| 2.0 16V (X 20 XEV) | | Gasolina | FWD | 1998 | 100 | 136 | 09.98-05.05 | ■ | |
| 2.0 16V | | Gasolina | FWD | 1998 | 118 | 160 | 10.99-05.05 | ■ | |
| 1.8 16V Dualfuel (Z 18 XE) | | Gasol./Gas (LPG) | FWD | 1796 | 87 | 118 | 02.98-07.04 | ■ | |

LISTA DE APLICACIONES - BUYERS GUIDE

| | | | | | | | | | |
|---|-------------------|------------------|-----|------|-----|-----|--|---|--|
| 1.8 16V Dualfuel | vehicles with ABS | Gasol./Gas (LPG) | FWD | 1796 | 92 | 125 | 07.02-12.03 | ■ | |
| 2.0 DI (X 20 DTL) | | Diesel | FWD | 1995 | 60 | 82 | 02.98-07.04 | ■ | |
| 2.0 DI (Y 20 DTL) | | Diesel | FWD | 1995 | 60 | 82 | 02.98-07.04 | ■ | |
| 2.0 DTI 16V (Y 20 DTH) | vehicles with ABS | Diesel | FWD | 1995 | 74 | 101 | 02.98-07.04 | ■ | |
| ASTRA Mk V (H) (A04) 08.04-10.12 | | | | | | | Estate (Compact car-C Segment) | | |
| 1.4 (L35) (Z 14 XEP) | | Gasolina | FWD | 1364 | 66 | 90 | 08.04-03.09 | ■ | |
| 1.6 (L35) (Z 16 XE1) | | Gasolina | FWD | 1598 | 77 | 105 | 08.04-03.09 | ■ | |
| 1.6 (L35) (Z 16 XEP) | | Gasolina | FWD | 1598 | 77 | 105 | 08.04-03.09 | ■ | |
| 1.6 (L35) (Z 16 XER) | 01/06- | Gasolina | FWD | 1598 | 85 | 115 | 08.04-03.11 | ■ | |
| 1.6 (L35) (A 16 LET) | 01/06- | Gasolina | FWD | 1598 | 132 | 180 | 08.04-03.09 | ■ | |
| 1.6 (L35) (Z 16 LET) | 01/06- | Gasolina | FWD | 1598 | 132 | 180 | 08.04-03.09 | ■ | |
| 1.8 (L35) (Z 18 XE) | | Gasolina | FWD | 1796 | 92 | 125 | 10.04-03.09 | ■ | |
| 1.8 (L35) (A 18 XER) | 01/08- | Gasolina | FWD | 1796 | 103 | 140 | 12.05-10.10 | ■ | |
| 1.8 (L35) (Z 18 XER) | 01/08- | Gasolina | FWD | 1796 | 103 | 140 | 12.05-10.10 | ■ | |
| 2.0 Turbo (L35) (Z 20 LEL) | -12/09 | Gasolina | FWD | 1998 | 125 | 170 | 08.04-10.10 | ■ | |
| 2.0 Turbo (L35) (Z 20 LER) | -12/09 | Gasolina | FWD | 1998 | 147 | 200 | 08.04-10.10 | ■ | |
| 1.3 CDTI (L35) (Z 13 DTH) | 01/05- | Diesel | FWD | 1248 | 66 | 90 | 08.04-03.09 | ■ | |
| 1.7 CDTI (L35) (Z 17 DTL) | | Diesel | FWD | 1686 | 59 | 80 | 08.04-05.09 | ■ | |
| 1.7 CDTI (L35) (Z 17 DTH) | | Diesel | FWD | 1686 | 74 | 100 | 08.04-03.09 | ■ | |
| 1.7 TD | 01/08- | Diesel | RWD | 1686 | 79 | 108 | 08.04-03.09 | ■ | |
| 1.7 CDTI (L35) (A 17 DTJ) | 01/07- | Diesel | FWD | 1686 | 81 | 110 | 08.04-10.12 | ■ | |
| 1.7 CDTI (L35) (Z 17 DTJ) | 01/07- | Diesel | FWD | 1686 | 81 | 110 | 08.04-10.12 | ■ | |
| 1.9 CDTI (L35) | 01/05- | Diesel | FWD | 1910 | 74 | 100 | 08.04-03.09 | ■ | |
| 1.9 CDTI | 01/05- | Diesel | RWD | 1910 | 88 | 120 | 08.04-03.09 | ■ | |
| 1.9 CDTI (L35) (Z 19 DT) | | Diesel | FWD | 1910 | 88 | 120 | 08.04-03.09 | ■ | |
| 1.9 CDTI 16V (L35) (Z 19 DTJ) | | Diesel | FWD | 1910 | 88 | 120 | 08.04-03.09 | ■ | |
| 1.9 CDTI (L35) (Z 19 DTH) | | Diesel | FWD | 1910 | 110 | 150 | 08.04-03.09 | ■ | |
| ASTRA Mk V (H) (A04) 01.04-03.11 | | | | | | | Hatchback (Compact car-C Segment) | | |
| 1.4 (L48) (Z 14 XEP) | | Gasolina | FWD | 1364 | 66 | 90 | 01.04-05.09 | ■ | |
| 1.6 (L48) (Z 16 XE1) | | Gasolina | FWD | 1598 | 77 | 105 | 01.04-05.09 | ■ | |
| 1.6 (L48) (Z 16 XEP) | | Gasolina | FWD | 1598 | 77 | 105 | 01.04-05.09 | ■ | |
| 1.6 (L48) (A 16 XER) | 01/06- | Gasolina | FWD | 1598 | 85 | 115 | 01.04-05.09 | ■ | |
| 1.6 (L48) (Z 16 XER) | 01/06- | Gasolina | FWD | 1598 | 85 | 115 | 01.04-05.09 | ■ | |
| 1.6 Turbo (L48) (A 16 LET) | | Gasolina | FWD | 1598 | 132 | 180 | 09.06-09.09 | ■ | |
| 1.6 Turbo (L48) (Z 16 LET) | | Gasolina | FWD | 1598 | 132 | 180 | 09.06-09.09 | ■ | |
| 1.8 (L48) (Z 18 XE) | | Gasolina | FWD | 1796 | 92 | 125 | 01.04-05.09 | ■ | |
| 1.8 (L48) (A 18 XER) | 01/06- | Gasolina | FWD | 1796 | 103 | 140 | 01.04-05.09 | ■ | |
| 1.8 (L48) (Z 18 XER) | 01/06- | Gasolina | FWD | 1796 | 103 | 140 | 01.04-05.09 | ■ | |
| 2.0 Turbo (L48) (Z 20 LEL) | | Gasolina | FWD | 1998 | 125 | 170 | 01.04-05.09 | ■ | |
| 2.0 Turbo (L48) (Z 20 LER) | | Gasolina | FWD | 1998 | 147 | 200 | 01.04-05.09 | ■ | |
| 2.0 Turbo (L48) (Z 20 LEH) | 01/05- | Gasolina | FWD | 1998 | 177 | 240 | 01.04-05.09 | ■ | |
| 1.3 CDTI (L48) (Z 13 DTH) | 01/05- | Diesel | FWD | 1248 | 66 | 90 | 01.04-05.09 | ■ | |
| 1.7 CDTI (L48) (Z 17 DTL) | | Diesel | FWD | 1686 | 59 | 80 | 01.04-05.09 | ■ | |
| 1.7 CDTI (L48) (Z 17 DTH) | | Diesel | FWD | 1686 | 74 | 100 | 01.04-05.09 | ■ | |
| 1.7 TD | 01/08- | Diesel | RWD | 1686 | 79 | 108 | 01.04-05.09 | ■ | |
| 1.7 CDTI (L48) (A 17 DTJ) | 01/07- | Diesel | FWD | 1686 | 81 | 110 | 01.04-03.11 | ■ | |
| 1.7 CDTI (L48) (Z 17 DTJ) | 01/07- | Diesel | FWD | 1686 | 81 | 110 | 01.04-03.11 | ■ | |
| 1.9 CDTI (L48) (Z 19 DT) | 01/05- | Diesel | FWD | 1910 | 88 | 120 | 01.04-05.09 | ■ | |
| 1.9 CDTI 16V (L48) (Z 19 DTJ) | | Diesel | FWD | 1910 | 88 | 120 | 01.04-05.09 | ■ | |
| 1.9 CDTI (L48) (Z 19 DTH) | | Diesel | FWD | 1910 | 110 | 150 | 01.04-05.09 | ■ | |

LISTA DE APLICACIONES - BUYERS GUIDE

| ASTRA Mk V (H) Sport Hatch (A04) 02.05-11.10 | | | | | | Hatchback (Compact car-C Segment) | | | |
|---|-------------------|----------|-----|------|-----|--|-------------|---|--|
| 1.4 i 16V (L08) (Z 14 XEP) | -12/09 | Gasolina | FWD | 1364 | 66 | 90 | 03.05-11.10 | ■ | |
| 1.6 (L08) (Z 16 XEP) | -12/09 | Gasolina | FWD | 1598 | 77 | 105 | 02.05-11.10 | ■ | |
| 1.6 i 16V (L08) (A 16 XER) | -12/09 | Gasolina | FWD | 1598 | 85 | 116 | 12.06-11.10 | ■ | |
| 1.6 i 16V (L08) (Z 16 XER) | -12/09 | Gasolina | FWD | 1598 | 85 | 116 | 12.06-11.10 | ■ | |
| 1.6 (L08) (A 16 LET) | -12/09 | Gasolina | FWD | 1598 | 132 | 179 | 10.06-11.10 | ■ | |
| 1.6 (L08) (Z 16 LET) | -12/09 | Gasolina | FWD | 1598 | 132 | 179 | 10.06-11.10 | ■ | |
| 1.8 (L08) (Z 18 XE) | -12/09 | Gasolina | FWD | 1796 | 92 | 125 | 02.05-11.10 | ■ | |
| 1.8 i 16V (L08) (A 18 XER) | -12/09 | Gasolina | FWD | 1796 | 103 | 140 | 03.07-11.10 | ■ | |
| 1.8 i 16V (L08) (Z 18 XER) | -12/09 | Gasolina | FWD | 1796 | 103 | 140 | 03.07-11.10 | ■ | |
| 2.0 Turbo (L08) (Z 20 LEL) | -12/09 | Gasolina | FWD | 1998 | 125 | 170 | 02.05-11.10 | ■ | |
| 2.0 VXR (L08) (Z 20 LEH) | | Gasolina | FWD | 1998 | 176 | 240 | 02.09-11.10 | ■ | |
| 1.3 CDTi (L08) (Z 13 DTH) | -12/09 | Diesel | FWD | 1248 | 66 | 90 | 04.05-11.10 | ■ | |
| 1.7 CDTi (L08) (Z 17 DTH) | -12/09 | Diesel | FWD | 1686 | 74 | 100 | 02.05-11.10 | ■ | |
| 1.7 CDTi (L08) (A 17 DTJ) | | Diesel | FWD | 1686 | 81 | 110 | 02.07-11.09 | ■ | |
| 1.7 CDTi (L08) (Z 17 DTJ) | | Diesel | FWD | 1686 | 81 | 110 | 02.07-11.09 | ■ | |
| 1.9 CDTi (L08) (Z 19 DTL) | -12/09 | Diesel | FWD | 1910 | 74 | 101 | 08.05-11.10 | ■ | |
| 1.9 CDTi (L08) (Z 19 DT) | -12/09 | Diesel | FWD | 1910 | 88 | 120 | 02.05-11.10 | ■ | |
| 1.9 CDTi (L08) (Z 19 DTH) | -12/09 | Diesel | FWD | 1910 | 110 | 150 | 02.05-11.10 | ■ | |
| ASTRA Mk V (H) TwinTop (A04) 09.05-08.11 | | | | | | Convertible (Compact car-C Segment) | | | |
| 1.6 (L67) (Z 16 XEP) | -12/09 | Gasolina | FWD | 1598 | 77 | 105 | 09.05-11.10 | ■ | |
| 1.6 i 16V (L67) (A 16 XER) | -12/09 | Gasolina | FWD | 1598 | 85 | 116 | 10.06-08.11 | ■ | |
| 1.6 i 16V (L67) (Z 16 XER) | -12/09 | Gasolina | FWD | 1598 | 85 | 116 | 10.06-08.11 | ■ | |
| 1.6 | -12/09 | Gasolina | FWD | 1598 | 132 | 179 | 10.06-11.10 | ■ | |
| 1.8 (L67) (A 18 XER) | -12/09 | Gasolina | FWD | 1796 | 103 | 140 | 05.08-11.10 | ■ | |
| 1.8 (L67) (Z 18 XER) | -12/09 | Gasolina | FWD | 1796 | 103 | 140 | 05.08-11.10 | ■ | |
| 2.0 (L67) (Z 20 LEL) | -12/06 | Gasolina | FWD | 1998 | 125 | 170 | 02.06-11.10 | ■ | |
| 2.0 Turbo (L67) (Z 20 LER) | -12/09 | Gasolina | FWD | 1998 | 147 | 200 | 01.06-11.10 | ■ | |
| 1.9 CDTi (L67) (Z 19 DTH) | -12/09 | Diesel | FWD | 1910 | 110 | 150 | 01.06-11.10 | ■ | |
| ASTRAVAN Mk IV (G) (T98) 01.93-08.06 | | | | | | Estate Van (Compact car-C Segment) | | | |
| 2.0 DI (X 20 DTL) | vehicles with ABS | Diesel | FWD | 1995 | 60 | 82 | 08.98-08.06 | ■ | |
| 2.0 DI (Y 20 DTL) | vehicles with ABS | Diesel | FWD | 1995 | 60 | 82 | 08.98-08.06 | ■ | |
| 2.0 DTI (Y 20 DTH) | | Diesel | FWD | 1995 | 74 | 100 | 04.04-08.06 | ■ | |
| ASTRAVAN Mk V (H) (A04) 03.05- | | | | | | Estate Van (Compact car-C Segment) | | | |
| 1.4 i (Z 14 XEP) | | Gasolina | FWD | 1364 | 66 | 90 | 03.05- | ■ | |
| 1.6 (Z 16 XE1) | | Gasolina | FWD | 1598 | 76 | 103 | 03.05- | ■ | |
| 1.6 (Z 16 XEP) | | Gasolina | FWD | 1598 | 76 | 103 | 03.05- | ■ | |
| 1.3 CDTi (Z 13 DTH) | | Diesel | FWD | 1248 | 66 | 90 | 08.05- | ■ | |
| 1.7 CDTi (Z 17 DTL) | | Diesel | FWD | 1686 | 59 | 80 | 03.05-07.06 | ■ | |
| 1.7 CDTi (Z 17 DTH) | | Diesel | FWD | 1686 | 74 | 101 | 03.05-11.11 | ■ | |
| 1.7 CDTi (A 17 DTJ) | | Diesel | FWD | 1686 | 81 | 110 | 06.11-12.13 | ■ | |
| 1.7 CDTi (Z 17 DTJ) | | Diesel | FWD | 1686 | 81 | 110 | 06.11-12.13 | ■ | |
| 1.7 CDTi (A 17 DTR) | | Diesel | FWD | 1686 | 92 | 125 | 11.11- | ■ | |
| 1.7 CDTi (Z 17 DTR) | | Diesel | FWD | 1686 | 92 | 125 | 11.11- | ■ | |
| 1.9 CDTi (Z 19 DT) | | Diesel | FWD | 1910 | 88 | 120 | 03.05-11.11 | ■ | |
| 1.9 CDTi (Z 19 DTH) | | Diesel | FWD | 1910 | 110 | 150 | 03.05-11.11 | ■ | |
| COMBO Mk II (C) (F25) 09.01-02.12 | | | | | | Box Body/MPV (LCVs-N1 Segment) | | | |
| 1.2 | 01/01- | Gasolina | FWD | 1195 | 54 | 74 | 09.01- | ■ | |

LISTA DE APLICACIONES - BUYERS GUIDE

| | | | | | | | | | |
|---|--|------------------|-----|------|-----|-----|--|---|--|
| 1.4 i 16V (Z 14 XEP) | discØ 280, increased payload, disc brak.rear axle, drum brak.rear axle | Gasolina | FWD | 1364 | 66 | 90 | 01.04-11.11 | ■ | |
| 1.4 16V (Z 14 XE) | increased payload | Gasolina | FWD | 1389 | 66 | 90 | 10.01-05.07 | ■ | |
| 1.6 (Z 16 SE) | increased payload, discØ 280, disc brak.rear axle | Gasolina | FWD | 1598 | 62 | 84 | 09.01-10.04 | ■ | |
| 1.6 (Z 16 SE) | increased payload, discØ 280, disc brak.rear axle | Gasolina | FWD | 1598 | 64 | 87 | 10.01-11.11 | ■ | |
| 1.6 CNG 16V (Y 16 YNG) | discØ 280, increased payload | Gasol./Gas (CNG) | FWD | 1598 | 69 | 94 | 06.06-02.12 | ■ | |
| 1.6 CNG 16V (Z 16 YNG) | discØ 280, increased payload | Gasol./Gas (CNG) | FWD | 1598 | 69 | 94 | 06.06-02.12 | ■ | |
| 1.6 CNG 16V (Z 16 YNG) | discØ 280, increased payload | Gasol./Gas (CNG) | FWD | 1598 | 71 | 97 | 04.05-02.12 | ■ | |
| 1.3 CDTI 16V (Y 13 DT) | discØ 280, increased payload, disc brak.rear axle, drum brak.rear axle | Diesel | FWD | 1248 | 51 | 69 | 09.04-02.12 | ■ | |
| 1.3 CDTI 16V (Z 13 DT) | discØ 280, increased payload, disc brak.rear axle, drum brak.rear axle | Diesel | FWD | 1248 | 51 | 69 | 09.04-02.12 | ■ | |
| 1.3 CDTI 16V (Z 13 DTJ) | increased payload, discØ 280 | Diesel | FWD | 1248 | 55 | 75 | 10.05-11.11 | ■ | |
| 1.7 DI 16V (Y 17 DTL) | increased payload, discØ 280, disc brak.rear axle | Diesel | FWD | 1686 | 48 | 65 | 09.01-11.11 | ■ | |
| 1.7 DTI 16V (Y 17 DT) | discØ 280, increased payload, disc brak.rear axle, drum brak.rear axle | Diesel | FWD | 1686 | 55 | 75 | 10.01-11.11 | ■ | |
| 1.7 CDTI 16V (Z 17 DTH) | discØ 280 | Diesel | FWD | 1686 | 74 | 101 | 12.04-11.11 | ■ | |
| COMBO TOUR Mk II (C) (F25) 09.01-02.12 | | | | | | | MPV (Large MPV-M1 Segment) | | |
| 1.4 (Z 14 XEP) | discØ 280, increased payload, disc brak.rear axle, drum brak.rear axle | Gasolina | FWD | 1364 | 66 | 90 | 10.04-09.10 | ■ | |
| 1.6 (Z 16 SE) | increased payload, discØ 280, disc brak.rear axle | Gasolina | FWD | 1598 | 64 | 87 | 10.01-06.04 | ■ | |
| 1.6 CNG (Z 16 YNG) | increased payload | Gasol./Gas (CNG) | FWD | 1598 | 69 | 94 | 06.06-09.10 | ■ | |
| 1.6 CNG (Z 16 YNG) | increased payload | Gasol./Gas (CNG) | FWD | 1598 | 71 | 97 | 04.05-02.12 | ■ | |
| 1.3 CDTI 16V (Z 13 DT) | discØ 280, increased payload, disc brak.rear axle, drum brak.rear axle | Diesel | FWD | 1248 | 51 | 69 | 09.04-09.06 | ■ | |
| 1.3 CDTI 16V (Z 13 DTJ) | increased payload, discØ 280 | Diesel | FWD | 1248 | 55 | 75 | 07.06-02.12 | ■ | |
| 1.7 DI 16V (Y 17 DTL) | increased payload, discØ 280, disc brak.rear axle | Diesel | FWD | 1686 | 48 | 65 | 09.01-06.04 | ■ | |
| 1.7 DTI 16V (Y 17 DT) | discØ 280, increased payload, disc brak.rear axle, drum brak.rear axle | Diesel | FWD | 1686 | 55 | 75 | 10.01-02.12 | ■ | |
| 1.7 CDTI 16V (Z 17 DTH) | discØ 280 | Diesel | FWD | 1686 | 74 | 101 | 12.04-09.10 | ■ | |
| CORSA Mk II (C) (X01) 08.00-04.07 | | | | | | | Hatchback (Supermini car-B Segment) | | |
| 1.7 CDTI 16V (F08, F68) (Z 17 DTH) | 01/04-, discØ 280 | Diesel | FWD | 1686 | 74 | 100 | 08.00-09.06 | ■ | |
| CORSA Mk III (D) (S07) 07.06-08.14 | | | | | | | Hatchback (Supermini car-B Segment) | | |
| 1.6 SRi (L08) (A 16 LEL) | | Gasolina | FWD | 1598 | 110 | 150 | 05.07-08.14 | ■ | |
| 1.6 SRi (L08) (Z 16 LEL) | | Gasolina | FWD | 1598 | 110 | 150 | 05.07-08.14 | ■ | |
| 1.6 VXR (L08) (A 16 LER) | | Gasolina | FWD | 1598 | 141 | 192 | 11.06-08.14 | ■ | |
| 1.6 VXR (L08) (B 16 LER) | | Gasolina | FWD | 1598 | 141 | 192 | 11.06-08.14 | ■ | |
| 1.6 VXR (L08) (Z 16 LER) | | Gasolina | FWD | 1598 | 141 | 192 | 11.06-08.14 | ■ | |
| 1.6 VXR (L08) (A 16 LES) | | Gasolina | FWD | 1598 | 150 | 204 | 06.11-08.14 | ■ | |
| 1.6 VXR (L08) (A 16 LES) | | Gasolina | FWD | 1598 | 154 | 209 | 06.11-08.14 | ■ | |
| 1.6 VXR (L08) (A 16 LES) | | Gasolina | FWD | 1598 | 155 | 211 | 06.11-03.12 | ■ | |

LISTA DE APLICACIONES - BUYERS GUIDE

| | | | | | Hatchback (Supermini car-B Segment) | | | | |
|---|------------------------------------|-------------------|-----|------|--|-----|-------------|---|--|
| CORSA Mk IV (E) (X15) 08.14- | | | | | | | | | |
| 1.0 (B 10 XFL) | Rim 16 | Gasolina | FWD | 999 | 66 | 90 | 08.14- | ■ | |
| 1.0 (D 10 XFL) | Rim 16 | Gasolina | FWD | 999 | 66 | 90 | 08.14- | ■ | |
| 1.0 (F 10 XFL) | Rim 16 | Gasolina | FWD | 999 | 66 | 90 | 08.14- | ■ | |
| 1.0 (B 10 XFT) | Rim 16 | Gasolina | FWD | 999 | 85 | 116 | 08.14- | ■ | |
| 1.0 (D 10 XFT) | Rim 16 | Gasolina | FWD | 999 | 85 | 116 | 08.14- | ■ | |
| 1.2 (B 12 XEL) | Rim 16 | Gasolina | FWD | 1229 | 51 | 69 | 08.14- | ■ | |
| 1.4 (B 14 NEJ) | Rim 16 | Gasolina | FWD | 1364 | 74 | 101 | 08.14- | ■ | |
| 1.4 (D 14 NEJ) | Rim 16 | Gasolina | FWD | 1364 | 74 | 101 | 08.14- | ■ | |
| 1.4 (B 14 NEH) | Rim 16 | Gasolina | FWD | 1364 | 110 | 150 | 07.15- | ■ | |
| 1.4 (B 14 XEJ) | Rim 16 | Gasolina | FWD | 1398 | 55 | 75 | 09.14- | ■ | |
| 1.4 (B 14 XEL) | Rim 16 | Gasolina | FWD | 1398 | 66 | 90 | 08.14- | ■ | |
| 1.4 (D 14 XEL) | Rim 16 | Gasolina | FWD | 1398 | 66 | 90 | 08.14- | ■ | |
| 1.6 VXR (B 16 LES) | Rim 16 | Gasolina | FWD | 1598 | 151 | 205 | 04.15- | ■ | |
| 1.4 LPG | Rim 16 | Gasol./G as (LPG) | FWD | 1398 | 66 | 90 | 08.14- | ■ | |
| 1.3 CDTi (B 13 DTC) | Rim 16 | Diesel | FWD | 1248 | 55 | 75 | 08.14- | ■ | |
| 1.3 CDTi (B 13 DTN) | Rim 16 | Diesel | FWD | 1248 | 55 | 75 | 08.14- | ■ | |
| 1.3 CDTi (B 13 DTE) | Rim 16 | Diesel | FWD | 1248 | 70 | 95 | 08.14- | ■ | |
| 1.3 CDTi (B 13 DTR) | Rim 16 | Diesel | FWD | 1248 | 70 | 95 | 08.14- | ■ | |
| CORSAVAN Mk II (C) (X01) 09.00-11.06 | | | | | Hatchback Van (LCVs-N1 Segment) | | | | |
| 1.7 DTI 16V (F08) (Y 17 DT) | | Diesel | FWD | 1686 | 55 | 75 | 09.00-06.06 | ■ | |
| CORSAVAN Mk IV (E) (X15) 10.14- | | | | | Hatchback Van (LCVs-N1 Segment) | | | | |
| 1.2 (B 12 XEL) | Rim 16 | Gasolina | FWD | 1229 | 51 | 69 | 10.14- | ■ | |
| 1.4 | Rim 16 | Gasolina | FWD | 1398 | 55 | 75 | 10.14- | ■ | |
| 1.3 CDTi (B 13 DTC) | Rim 16 | Diesel | FWD | 1248 | 55 | 75 | 10.14- | ■ | |
| 1.3 CDTi (B 13 DTN) | Rim 16 | Diesel | FWD | 1248 | 55 | 75 | 10.14- | ■ | |
| 1.3 CDTi (B 13 DTE) | Rim 16 | Diesel | FWD | 1248 | 70 | 95 | 10.14- | ■ | |
| 1.3 CDTi (B 13 DTR) | Rim 16 | Diesel | FWD | 1248 | 70 | 95 | 10.14- | ■ | |
| MERIVA Mk I (A) (X03) 01.03-06.10 | | | | | MPV (Mini MPV-M1 Segment) | | | | |
| 1.4 16V Twinport (Z 14 XEP) | 01/04-, Rim 15, discØ 280, RimHo 5 | Gasolina | FWD | 1364 | 66 | 90 | 01.03-06.10 | ■ | |
| 1.6 i (Z 16 SE) | RimHo 5 | Gasolina | FWD | 1598 | 64 | 87 | 01.03-06.10 | ■ | |
| 1.6 i 16V (Z 16 XE) | discØ 280 | Gasolina | FWD | 1598 | 74 | 100 | 01.03-09.05 | ■ | |
| 1.6 i 16V Twinport (Z 16 XEP) | 01/06-, discØ 280 | Gasolina | FWD | 1598 | 77 | 105 | 05.03-06.10 | ■ | |
| 1.6 Turbo (Z 16 LET) | | Gasolina | FWD | 1598 | 132 | 180 | 05.06-06.10 | ■ | |
| 1.8 i 16V (Z 18 XE) | discØ 280 | Gasolina | FWD | 1796 | 92 | 125 | 05.03-06.10 | ■ | |
| 1.3 CDTi (Y 13 DT) | discØ 280 | Diesel | FWD | 1248 | 51 | 69 | 04.05-06.10 | ■ | |
| 1.3 CDTi (Z 13 DT) | discØ 280 | Diesel | FWD | 1248 | 51 | 69 | 04.05-06.10 | ■ | |
| 1.3 CDTi (Z 13 DTJ) | 01/06-, discØ 280 | Diesel | FWD | 1248 | 55 | 75 | 01.03-10.09 | ■ | |
| 1.7 DTI (Y 17 DT) | discØ 280 | Diesel | FWD | 1686 | 55 | 75 | 06.03-06.10 | ■ | |
| 1.7 CDTi (Z 17 DTH) | 01/04-, discØ 280 | Diesel | FWD | 1686 | 74 | 100 | 09.03-06.08 | ■ | |
| 1.7 CDTi | | Diesel | RWD | 1686 | 92 | 125 | 08.06-06.10 | ■ | |
| MERIVA Mk II (B) (S10) 06.10- | | | | | MPV (Mini MPV-M1 Segment) | | | | |
| 1.4 (A 14 NEL) | | Gasolina | FWD | 1364 | 88 | 120 | 06.10-10.13 | ■ | |
| 1.4 (B 14 NEL) | | Gasolina | FWD | 1364 | 88 | 120 | 06.10-10.13 | ■ | |
| 1.4 (A 14 NET) | | Gasolina | FWD | 1364 | 103 | 140 | 06.10-10.13 | ■ | |
| 1.4 (B 14 NET) | | Gasolina | FWD | 1364 | 103 | 140 | 06.10-10.13 | ■ | |
| 1.4 (A 14 XER) | | Gasolina | FWD | 1398 | 74 | 101 | 06.10-03.17 | ■ | |
| 1.4 (B 14 XER) | | Gasolina | FWD | 1398 | 74 | 101 | 06.10-03.17 | ■ | |

LISTA DE APLICACIONES - BUYERS GUIDE

| | | | | | | | | | |
|---|---------------------|------------------|-----|------|-----|-----|-------------------------------------|---|--|
| 1.4 LPG (A 14 NEL) | discØ 280 | Gasol./Gas (LPG) | FWD | 1364 | 88 | 120 | 06.11-03.17 | ■ | |
| 1.3 CDTi (A 13 DTC) | | Diesel | FWD | 1248 | 55 | 75 | 06.10-10.13 | ■ | |
| 1.3 CDTi (A 13 DTE) | | Diesel | FWD | 1248 | 70 | 95 | 06.10-11.14 | ■ | |
| 1.6 CDTi (B 16 DTC) | | Diesel | FWD | 1598 | 70 | 95 | 01.14-01.17 | ■ | |
| 1.6 CDTi (B 16 DTE) | | Diesel | FWD | 1598 | 81 | 110 | 07.14-03.17 | ■ | |
| 1.6 CDTi (B 16 DTL) | | Diesel | FWD | 1598 | 81 | 110 | 07.14-03.17 | ■ | |
| 1.6 CDTi (B 16 DTN) | | Diesel | FWD | 1598 | 81 | 110 | 07.14-03.17 | ■ | |
| 1.6 CDTi (B 16 DTH) | | Diesel | FWD | 1598 | 100 | 136 | 08.13-01.17 | ■ | |
| 1.7 CDTi (A 17 DT) | discØ 280 | Diesel | FWD | 1686 | 74 | 101 | 06.10-01.17 | ■ | |
| 1.7 CDTi (A 17 DTC) | discØ 280 | Diesel | FWD | 1686 | 81 | 110 | 06.10-06.15 | ■ | |
| 1.7 CDTi (A 17 DTI) | discØ 280 | Diesel | FWD | 1686 | 81 | 110 | 06.10-06.15 | ■ | |
| 1.7 CDTi (A 17 DTS) | discØ 280 | Diesel | FWD | 1686 | 96 | 131 | 06.10-10.13 | ■ | |
| ZAFIRA Mk I (A) (T98) 11.98-08.05 | | | | | | | MPV (Compact MPV-M1 Segment) | | |
| 1.6 16V (X 16 XEL) | | Gasolina | FWD | 1598 | 74 | 101 | 04.99-08.05 | ■ | |
| 1.6 16V (Z 16 XE) | | Gasolina | FWD | 1598 | 74 | 101 | 04.99-08.05 | ■ | |
| 1.8 16V (X 18 XE1) | | Gasolina | FWD | 1796 | 85 | 116 | 05.99-08.00 | ■ | |
| 1.8 16V (Z 18 XE) | | Gasolina | FWD | 1796 | 92 | 125 | 09.00-08.05 | ■ | |
| 2.0 (Z 20 LET) | | Gasolina | FWD | 1998 | 147 | 199 | 06.02-06.05 | ■ | |
| 2.2 16V (Z 22 SE) | | Gasolina | FWD | 2198 | 108 | 147 | 11.98-08.04 | ■ | |
| 1.6 Dualfuel (X 16 XEL) | | Gasol./Gas (LPG) | FWD | 1598 | 74 | 101 | 11.98-08.05 | ■ | |
| 1.8 Dualfuel (Z 18 XE) | | Gasol./Gas (LPG) | FWD | 1796 | 92 | 125 | 09.00-08.05 | ■ | |
| 1.6 CNG (Z 16 YNG) | | Gasol./Gas (CNG) | FWD | 1598 | 71 | 97 | 09.01-06.05 | ■ | |
| 2.0 DI 16V (X 20 DTL) | | Diesel | FWD | 1995 | 60 | 82 | 10.99-08.05 | ■ | |
| 2.0 DTI 16V (Y 20 DTH) | | Diesel | FWD | 1995 | 74 | 101 | 04.99-08.05 | ■ | |
| ZAFIRA Mk II (B) (A05) 04.05-11.14 | | | | | | | MPV (Compact MPV-M1 Segment) | | |
| 1.6 (Z 16 XE1) | | Gasolina | FWD | 1598 | 77 | 105 | 07.05-11.14 | ■ | |
| 1.6 (Z 16 XEP) | | Gasolina | FWD | 1598 | 77 | 105 | 07.05-11.14 | ■ | |
| 1.6 (A 16 XER) | | Gasolina | FWD | 1598 | 85 | 115 | 12.07-11.14 | ■ | |
| 1.6 (Z 16 XER) | | Gasolina | FWD | 1598 | 85 | 115 | 12.07-11.14 | ■ | |
| 1.8 (A 18 XEL) | discØ 280 | Gasolina | FWD | 1796 | 88 | 120 | 04.13-11.14 | ■ | |
| 1.8 (A 18 XER) | | Gasolina | FWD | 1796 | 103 | 140 | 04.05-11.14 | ■ | |
| 1.8 (Z 18 XER) | | Gasolina | FWD | 1796 | 103 | 140 | 04.05-11.14 | ■ | |
| 2.0 (Z 20 LER) | not police vehicles | Gasolina | FWD | 1998 | 147 | 200 | 07.05-11.14 | ■ | |
| 2.0 (Z 20 LEH) | | Gasolina | FWD | 1998 | 176 | 240 | 01.06-11.14 | ■ | |
| 2.2 (Z 22 YH) | not police vehicles | Gasolina | FWD | 2198 | 110 | 150 | 07.05-11.14 | ■ | |
| 1.7 CDTi (A 17 DTJ) | not police vehicles | Diesel | FWD | 1686 | 81 | 110 | 04.09-11.14 | ■ | |
| 1.7 CDTi (Z 17 DTJ) | not police vehicles | Diesel | FWD | 1686 | 81 | 110 | 04.09-11.14 | ■ | |
| 1.7 CDTi (A 17 DTR) | not police vehicles | Diesel | FWD | 1686 | 92 | 125 | 01.08-11.14 | ■ | |
| 1.9 CDTi (Z 19 DT) | not police vehicles | Diesel | FWD | 1910 | 88 | 120 | 07.05-11.14 | ■ | |
| 1.9 CDTi (Z 19 DTH) | not police vehicles | Diesel | FWD | 1910 | 110 | 150 | 07.05-11.14 | ■ | |