

LISTA DE APLICACIONES - BUYERS GUIDE

181877



Qty: 300

Weight: 1.523

O.E.M.	MAKE
04465-0D050	TOYOTA
04465-0D050-000	DAIHATSU
04465-0D120	TOYOTA
04465-0D210	TOYOTA
04465-YZZDS	TOYOTA
86 60 000 773	RENAULT
86 60 004 540	RENAULT

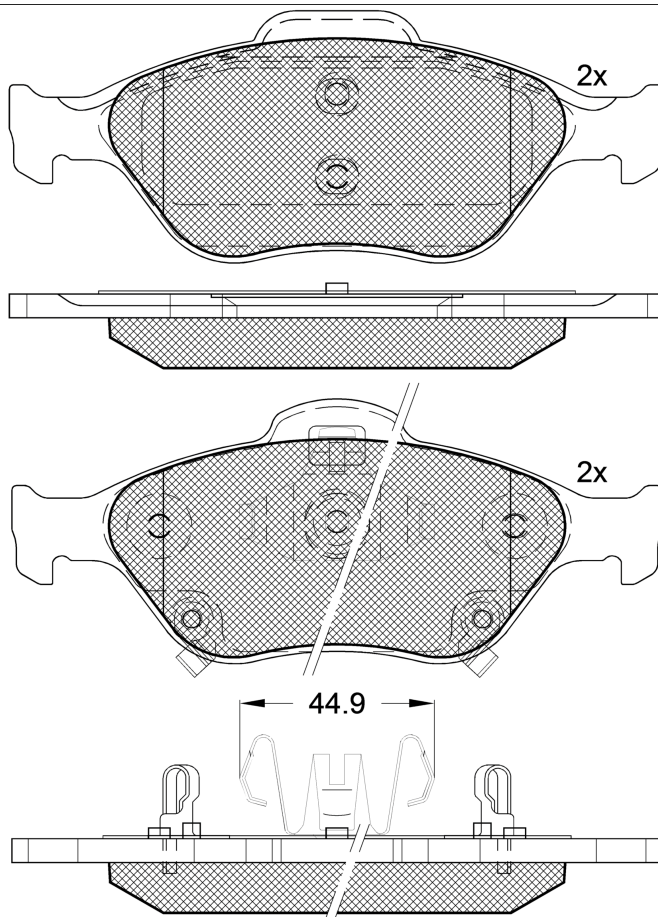

181877



90R-01111/200



Ate - Teves

150.1x61.17x17.8

150.3x58.5x17.8

WVA	FMSI
23202	D2003-9233
24022	
24023	
24952	

MAKE
DAIHATSU
TOYOTA



Trac.	CC	Kw	CV			Front / Rear
-------	----	----	----	--	--	--------------

DAIHATSU

CHARADE VI 05.11-

Hatchback (Supermini car-B Segment)

1.33 16V (1NR-FE)	France	Gasolina	FWD	1329	73	99	05.11-	■
-------------------	--------	----------	-----	------	----	----	--------	---

TOYOTA

YARIS II / VITZ (_P9_) 01.05-

Hatchback (Supermini car-B Segment)

1.0 VVT-i (KSP90_, KSP90R) (1KR-FE)		Gasolina	FWD	998	51	69	08.05-12.11	■
1.0 VVT-i (KSP90)	France	Gasolina	FWD	998	52	71	11.05-11.10	■
1.3 4WD (NCP95) (2NZ-FE)		Gasolina	4WD	1298	64	87	01.05-11.10	■
1.3 4WD (NCP95) (2SZ-FE)		Gasolina	4WD	1298	64	87	01.05-11.10	■
1.3 VVT-i (SCP90_, SCP90R) (2SZ-FE)		Gasolina	FWD	1298	64	87	08.05-11.10	■
1.33 VVT-i (NSP90_, NSP90R) (1NR-FE)		Gasolina	FWD	1329	73	99	07.10-05.11	■
1.33 VVT-i (NSP90_, NSP90R) (1NR-FE)		Gasolina	FWD	1329	74	100	11.08-12.11	■
1.5 (NCP91_, NCP91R) (1NZ-FE)	-12/11	Gasolina	FWD	1497	80	109	11.05-12.14	■
1.8 VVTi	-12/11	Gasolina	FWD	1794	97	132	11.05-	■
1.8 VVTi (ZSP90_, ZSP90R) (2ZR-FE)		Gasolina	FWD	1798	98	133	01.07-12.11	■
1.0 GPL (KSP90_) (1KR-FE)		Gasol./Gas (LPG)	FWD	998	51	69	01.06-12.11	■
1.4 D-4D (NLP90_, NLP90R) (1ND-TV)	-12/11	Diesel	FWD	1364	66	90	08.05-12.12	■

YARIS III / VITZ (_P13_) 10.12-

Hatchback Van (Supermini car-B Segment)

1.0 VVTi (KSP130) (1KR-FE)		Gasolina	FWD	998	51	69	07.14-06.20	■
1.0 VVTi (KSP130) (1KR-FE)		Gasolina	FWD	998	53	72	06.18-06.20	■
1.3 VVTi (NSP130) (1NR-FE)		Gasolina	FWD	1329	73	99	10.12-03.17	■
1.5 VVTi (NSP131) (2NR-FKE)		Gasolina	FWD	1496	82	111	03.17-06.20	■
1.5 Hybrid (NHP130) (1NZ-FXE)		Gasol./eléc.	FWD	1497	74	101	04.15-06.20	■

LISTA DE APLICACIONES - BUYERS GUIDE

1.4 D4d (NLP130) (1ND-TV)		Diesel	FWD	1364	66	90	07.14-05.18	■	
YARIS III / VITZ (_P13_) 12.10-					Hatchback (Supermini car-B Segment)				
1.0 (KSP130_, KSP130) (1KR-FE)		Gasolina	FWD	998	51	69	12.10-06.20	■	
1.0 (KSP130) (1KR-FE)		Gasolina	FWD	998	53	72	06.18-06.20	■	
1.3 (NSP130_, NSP130) (1NR-FE)		Gasolina	FWD	1329	73	99	09.11-03.17	■	
1.3 (NSP130_, NSP130) (1NR-FKE)		Gasolina	FWD	1329	73	99	09.11-03.17	■	
1.5 (NSP131_) (2NR-FKE)		Gasolina	FWD	1496	82	112	03.17-06.20	■	
1.5 Hybrid (NHP130_) (1NZ-FXE)	Eq.V_ Latinamerica	Gasol./el éc.	FWD	1497	74	101	04.15-03.17	■	
1.5 Hybrid (NHP130_, NHP130) (1NZ-FXE)	Eq.V_ Latinamerica	Gasol./el éc.	FWD	1497	74	101	03.12-06.20	■	
1.4 D (NLP130_, NLP130) (1ND-TV)		Diesel	FWD	1364	66	90	09.11-05.18	■	
YARIS / VIOS / BELTA (_P9_) 08.05-					Saloon (Supermini car-B Segment)				
1.0 (KSP92_, KSP92R) (1KR-FE)		Gasolina	FWD	998	52	71	09.05-10.13	■	
1.3 (NCP92_, SCP92_, NCP92R) (2NZ-FE)		Gasolina	FWD	1298	64	87	09.05-10.13	■	
1.3 (NCP92_, SCP92_, NCP92R) (2SZ-FE)		Gasolina	FWD	1298	64	87	09.05-10.13	■	
1.3 4WD (NCP92_, NCP96_, NCP96R, NCP92R) (2NZ-FE)		Gasolina	4WD	1298	64	87	09.05-04.13	■	
1.3 (NCP92_, NCP92R) (2NZ-FE)		Gasolina	FWD	1299	63	86	01.06-04.13	■	
1.5		Gasolina	FWD	1497	79	107	09.10-	■	
1.5 (NCP93) (1NZ-FE)	-12/11	Gasolina	FWD	1497	80	109	01.06-12.13	■	
1.5		Gasolina	FWD	1497	81	110	08.07-	■	