

LISTA DE APLICACIONES - BUYERS GUIDE

181942



8 424073 099051

Qty: 300

Weight: 1.985

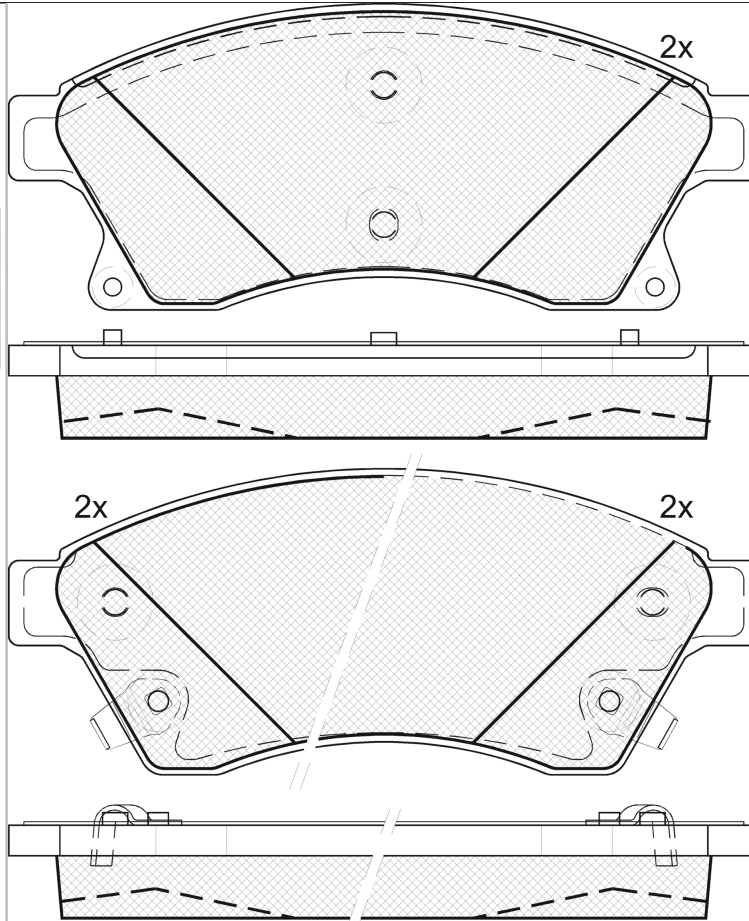

181942



E 9 90R-01111/2690

Mando

148.1x60.4x19

WVA

25076

25077

25078

FMSI

D1497-8697

D1522-8697

MAKE

CHEVROLET

CHEVROLET (SGM)

HOLDEN

NISSAN

OPEL

VAUXHALL



Trac.	CC	Kw	CV
-------	----	----	----



Front / Rear

CHEVROLET

AVEO II / SONIC (T300) 03.11-

Hatchback (Supermini car-B Segment)

Model	Rim	Gasolina	FWD	CC	Kw	CV	Year	Icon
1.2 (LWD)	Rim 15	Gasolina	FWD	1229	51	69	03.11-	■
1.2 (LDC)	Rim 15	Gasolina	FWD	1229	63	86	03.11-	■
1.4 Turbo (LUJ)	Rim 15	Gasolina	FWD	1364	103	140	08.13-	■
1.4 (A 14 XER)	Rim 15	Gasolina	FWD	1398	74	101	03.11-	■
1.4 (LDD)	Rim 15	Gasolina	FWD	1398	74	101	03.11-	■
1.4	Rim 15	Gasolina	FWD	1399	76	103	12.12-	■
1.6 (LDE)	Rim 15	Gasolina	FWD	1598	85	116	03.11-	■
1.6	Rim 15	Gasolina	FWD	1598	88	120	06.11-	■
1.6	Rim 15	Gasolina	FWD	1598	89	121	12.12-	■
1.2 LPG (LDC)	Rim 15	Gasol./Gas (LPG)	FWD	1229	63	86	11.12-12.15	■
1.6 Flex	Rim 15	Gasol./Etanol	FWD	1598	88	120	06.12-12.14	■
1.3 D (LDV)	Rim 15	Diesel	FWD	1248	55	75	07.11-12.15	■
1.3 D (LSF)	Rim 15	Diesel	FWD	1248	70	95	07.11-12.15	■
1.3 CDTi	Rim 15	Diesel	RWD	1295	55	75	07.11-	■

AVEO II / SONIC (T300) 03.11-

Saloon (Supermini car-B Segment)

Model	Rim	Gasolina	FWD	CC	Kw	CV	Year	Icon
1.2 (LWD)	Rim 15	Gasolina	FWD	1229	51	69	03.11-	■
1.2 (LDC)	Rim 15	Gasolina	FWD	1229	63	86	03.11-	■
1.4 (A 14 XER)	Rim 15	Gasolina	FWD	1398	74	100	07.11-	■
1.4 (LDD)	Rim 15	Gasolina	FWD	1398	74	100	07.11-	■
1.4	Rim 15	Gasolina	FWD	1399	76	103	12.12-	■
1.6 (LDE)	Rim 15	Gasolina	FWD	1598	85	116	03.11-	■
1.6	Rim 15	Gasolina	FWD	1598	88	120	06.11-	■

LISTA DE APLICACIONES - BUYERS GUIDE

1.6	Rim 15	Gasolina	FWD	1598	89	121	12.12-	■
1.2 LPG (LDC)	Rim 15	Gasol./Gas (LPG)	FWD	1229	63	86	11.12-12.15	■
1.6 Flexfuel	Rim 15	Gasol./Etanol	FWD	1598	88	120	06.12-	■
1.3 D (LDV)	Rim 15	Diesel	FWD	1248	55	75	07.11-12.15	■
1.3 D (LSF)	Rim 15	Diesel	FWD	1248	70	95	07.11-12.15	■
CRUZE I (J305) 12.10-				Hatchback (Supermini car-B Segment)				
1.4 (A 14 NET)		Gasolina	FWD	1364	103	140	06.12-	■
1.4 (LUJ)		Gasolina	FWD	1364	103	140	06.12-	■
1.4 (LDD)		Gasolina	FWD	1398	74	101	07.13-12.15	■
1.6 (LXT)		Gasolina	FWD	1598	80	109	01.12-	■
1.6 (LDE)	Rim 15	Gasolina	FWD	1598	86	117	12.12-	■
1.6	Rim 15	Gasolina	FWD	1598	89	121	12.12-	■
1.6 (LDE)	Rim 15	Gasolina	FWD	1598	91	124	06.11-	■
1.6 T	Rim 15	Gasolina	FWD	1598	135	184	12.12-	■
1.8 (2H0)	Rim 15	Gasolina	FWD	1796	103	140	10.11-	■
1.8 (2H0)	Rim 15	Gasolina	FWD	1796	104	141	06.11-	■
1.8 Flex	Rim 15	Gasolina	FWD	1796	106	144	10.12-	■
1.8	Rim 15	Gasolina	FWD	1796	108	147	12.12-	■
1.8 LPG (2H0)		Gasol./Gas (LPG)	FWD	1796	104	141	06.11-12.15	■
1.7 TD (LKR)		Diesel	FWD	1686	81	110	08.13-12.15	■
1.7 D (LUD)		Diesel	FWD	1686	96	131	01.12-12.15	■
2.0 CDI		Diesel	RWD	1991	110	150	01.12-	■
2.0 CDI (LNP)	Rim 15	Diesel	FWD	1998	120	163	06.11-	■
CRUZE I (J300) 05.09-				Saloon (Supermini car-B Segment)				
1.4 (LUJ)		Gasolina	FWD	1364	103	140	09.10-	■
1.4 (LDD)		Gasolina	FWD	1398	74	101	07.13-	■
1.6 (LXT)	Rim 15	Gasolina	FWD	1598	80	109	05.09-	■
1.6 (LDE)	Rim 15	Gasolina	FWD	1598	83	113	05.09-	■
1.6	Rim 15	Gasolina	FWD	1598	86	117	12.12-	■
1.6 (LDE)		Gasolina	FWD	1598	86	117	12.12-	■
1.6	Rim 15	Gasolina	FWD	1598	89	121	12.12-	■
1.6 (LDE)	Rim 15	Gasolina	FWD	1598	91	124	05.09-	■
1.6 T	Rim 15	Gasolina	FWD	1598	135	184	12.12-	■
1.8 (LUW)	Rim 15	Gasolina	FWD	1796	103	140	11.09-	■
1.8 (LWE)	Rim 15	Gasolina	FWD	1796	103	140	11.09-	■
1.8 (2H0)	Rim 15	Gasolina	FWD	1796	104	141	05.09-	■
1.8 Flex	Rim 15	Gasolina	FWD	1796	106	144	01.11-	■
1.8	Rim 15	Gasolina	FWD	1796	108	147	12.12-	■
1.8 LPG (2H0)		Gasol./Gas (LPG)	FWD	1796	104	141	06.11-	■
1.7 TD (LKR)		Diesel	FWD	1686	81	110	11.13-	■
1.7 D (LUD)		Diesel	FWD	1686	96	131	01.12-	■
2.0 CDI		Diesel	FWD	1991	90	123	05.09-	■
2.0 CDI (LLW)	Rim 15	Diesel	FWD	1991	92	125	05.09-05.11	■
2.0 CDI (LLW)	Rim 15	Diesel	FWD	1991	110	150	05.09-	■
2.0 CDI (LNP)	Rim 15	Diesel	FWD	1998	120	163	08.10-	■
CRUZE I Station Wagon (J308) 08.12-				Estate (Supermini car-B Segment)				
1.4 (LUJ)	Rim 15	Gasolina	FWD	1364	103	140	08.12-	■
1.4 (LDD)		Gasolina	FWD	1398	74	101	07.13-12.15	■

LISTA DE APLICACIONES - BUYERS GUIDE

1.6 (LDE)	Rim 15	Gasolina	FWD	1598	86	117	12.12-12.15	■
1.6	Rim 15	Gasolina	FWD	1598	89	121	12.12-	■
1.6 (LDE)	Rim 15	Gasolina	FWD	1598	91	124	08.12-12.15	■
1.6 T	Rim 15	Gasolina	FWD	1598	135	184	12.12-	■
1.8 (2H0)	Rim 15	Gasolina	FWD	1796	104	141	08.12-	■
1.8	Rim 15	Gasolina	FWD	1796	108	147	12.12-	■
1.7 TD (LKR)		Diesel	FWD	1686	81	110	11.13-12.15	■
1.7 TD (LUD)	Rim 15	Diesel	FWD	1686	96	131	08.12-	■
2.0 TD (LNP)	Rim 15	Diesel	FWD	1998	120	163	08.12-	■
CHEVROLET (SGM)								
AVEO II (SJ1) 05.11-						Hatchback (Supermini car-B Segment)		
1.4	Rim 15	Gasolina	FWD	1399	76	103	05.11-	■
1.6	Rim 15	Gasolina	FWD	1598	89	121	05.11-	■
AVEO II (SJ1) 03.11-						Saloon (Supermini car-B Segment)		
1.4	Rim 15	Gasolina	FWD	1399	76	103	05.11-	■
1.6	Rim 15	Gasolina	FWD	1598	89	121	05.11-	■
HOLDEN								
CRUZE II (JG) 06.09-03.11						Saloon (Supermini car-B Segment)		
1.4 i Turbo		Gasolina	FWD	1364	103	140	03.11-	■
NISSAN								
ROGUE 01.07-12.15						SUV (Compact SUV-J Segment)		
2.5		Gasolina	FWD	2488	124	169	01.10-11.13	■
2.5 AWD		Gasolina	4WD	2488	124	169	01.10-11.13	■
2.5		Gasolina	FWD	2488	125	170	01.10-11.13	■
2.5 AWD (QR25DE)		Gasolina	4WD	2488	125	170	01.10-11.13	■
OPEL								
ASTRA J (P10) 09.09-10.15						Estate Van (Compact car-C Segment)		
1.3 CDTI (35) (A 13 DTE)		Diesel	FWD	1248	70	95	10.12-10.15	■
ASTRA J (P10) 09.09-10.15						Hatchback Van (Compact car-C Segment)		
1.3 CDTI (68) (A 13 DTE)		Diesel	FWD	1248	70	95	05.13-10.15	■
ASTRA J (P10) 09.09-04.16						Hatchback (Compact car-C Segment)		
1.4 Turbo (68) (A 14 NEL)		Gasolina	FWD	1364	88	120	10.10-10.15	■
1.4 Turbo (68) (B 14 NEL)		Gasolina	FWD	1364	88	120	10.10-10.15	■
1.4 Turbo (68) (A 14 NET)		Gasolina	FWD	1364	103	140	12.09-10.15	■
1.4 Turbo (68) (B 14 NET)		Gasolina	FWD	1364	103	140	12.09-10.15	■
1.4 (68) (A 14 XEL)		Gasolina	FWD	1398	64	87	12.09-10.15	■
1.4 (68) (A 14 XER)		Gasolina	FWD	1398	74	100	12.09-10.15	■
1.4 (68) (B 14 XER)		Gasolina	FWD	1398	74	100	12.09-10.15	■
1.6 (68) (A 16 XER)		Gasolina	FWD	1598	85	115	12.09-10.15	■
1.6 (68) (B 16 XER)		Gasolina	FWD	1598	85	115	12.09-10.15	■
1.4 LPG (68) (A 14 NET)		Gasol./Gas (LPG)	FWD	1364	103	140	01.12-10.15	■
1.3 CDTI (68) (A 13 DTE)		Diesel	FWD	1248	70	95	12.09-10.15	■
ASTRA J 06.12-						Saloon (Compact car-C Segment)		
1.4 Turbo (69) (A 14 NEL)		Gasolina	FWD	1364	88	120	06.12-10.15	■
1.4 Turbo (69) (B 14 NEL)		Gasolina	FWD	1364	88	120	06.12-10.15	■
1.4 Turbo (69) (A 14 NET)		Gasolina	FWD	1364	103	140	06.12-06.18	■
1.4 Turbo (69) (B 14 NET)		Gasolina	FWD	1364	103	140	06.12-06.18	■

LISTA DE APLICACIONES - BUYERS GUIDE

1.4 (A 14 XEL)		Gasolina	FWD	1398	64	87	01.14-10.15	■	
1.4 (69) (A 14 XER)		Gasolina	FWD	1398	74	101	06.12-10.15	■	
1.4 (69) (B 14 XER)		Gasolina	FWD	1398	74	101	06.12-10.15	■	
1.6 (69) (A 16 XER)		Gasolina	FWD	1598	85	116	06.12-06.18	■	
1.6 (69) (B 16 XER)		Gasolina	FWD	1598	85	116	06.12-06.18	■	
1.4 Turbo LPG (69) (A 14 NET)		Gasol./Gas (LPG)	FWD	1364	103	140	07.14-06.18	■	
1.3 CDTI (69) (A 13 DTE)		Diesel	FWD	1248	70	95	06.12-10.15	■	
ASTRA J GTC 10.11-							Hatchback (Compact car-C Segment)		
1.4 (08) (A 14 NEL)		Gasolina	FWD	1364	88	120	10.11-04.18	■	
1.4 (08) (B 14 NEL)		Gasolina	FWD	1364	88	120	10.11-04.18	■	
1.4 Turbo (08) (A 14 NET)		Gasolina	FWD	1364	103	140	10.11-04.18	■	
1.4 Turbo (08) (B 14 NET)		Gasolina	FWD	1364	103	140	10.11-04.18	■	
1.4 (08) (A 14 XER)		Gasolina	FWD	1398	74	101	10.11-11.13	■	
2.0 CDTI (08) (A 20 DTH)		Diesel	FWD	1956	96	131	01.12-10.15	■	
ASTRA J Sports Tourer (P10) 10.10-							Estate (Compact car-C Segment)		
1.4 Turbo (35) (A 14 NEL)		Gasolina	FWD	1364	88	120	10.10-10.15	■	
1.4 Turbo (35) (B 14 NEL)		Gasolina	FWD	1364	88	120	10.10-10.15	■	
1.4 Turbo (35) (A 14 NET)		Gasolina	FWD	1364	103	140	10.10-10.15	■	
1.4 Turbo (35) (B 14 NET)		Gasolina	FWD	1364	103	140	10.10-10.15	■	
1.4 (35) (A 14 XEL)		Gasolina	FWD	1398	64	87	10.10-10.15	■	
1.4 (35) (A 14 XER)		Gasolina	FWD	1398	74	101	10.10-10.15	■	
1.4 (35) (B 14 XER)		Gasolina	FWD	1398	74	101	10.10-10.15	■	
1.6 (35) (A 16 XER)		Gasolina	FWD	1598	85	116	10.10-10.15	■	
1.6 (35) (B 16 XER)		Gasolina	FWD	1598	85	116	10.10-10.15	■	
1.4 LPG (35) (A 14 NET)		Gasol./Gas (LPG)	FWD	1364	103	140	12.11-10.15	■	
1.3 CDTI (35) (A 13 DTE)		Diesel	FWD	1248	70	95	10.10-10.14	■	
VAUXHALL									
ASTRA Mk VI (J) (P10) 10.10-							Estate (Compact car-C Segment)		
1.4 Turbo (A 14 NET)		Gasolina	FWD	1364	103	140	10.10-10.15	■	
1.4 (A 14 XEL)		Gasolina	FWD	1398	64	87	10.10-10.15	■	
1.4 (A 14 XER)		Gasolina	FWD	1398	74	101	10.10-10.15	■	
1.4 (B 14 XER)		Gasolina	FWD	1398	74	101	10.10-10.15	■	
1.6 (A 16 XER)		Gasolina	FWD	1598	85	116	10.10-10.15	■	
1.6 (B 16 XER)		Gasolina	FWD	1598	85	116	10.10-10.15	■	
1.3 CDTi (A 13 DTE)		Diesel	FWD	1248	70	95	10.10-10.15	■	
ASTRA Mk VI (J) (P10) 12.09-							Hatchback (Compact car-C Segment)		
1.4 Turbo (A 14 NEL)		Gasolina	FWD	1364	88	120	08.10-10.15	■	
1.4 Turbo (A 14 NET)		Gasolina	FWD	1364	103	140	12.09-10.15	■	
1.4 Turbo (B 14 NET)		Gasolina	FWD	1364	103	140	12.09-10.15	■	
1.4 Turbo (D 14 NET)		Gasolina	FWD	1364	103	140	12.09-10.15	■	
1.4 (A 14 XEL)		Gasolina	FWD	1398	64	87	12.09-10.15	■	
1.4 (A 14 XER)		Gasolina	FWD	1398	74	100	12.09-10.15	■	
1.4 (B 14 XER)		Gasolina	FWD	1398	74	100	12.09-10.15	■	
1.6 (A 16 XER)		Gasolina	FWD	1598	85	115	12.09-10.15	■	
1.6 (B 16 XER)		Gasolina	FWD	1598	85	115	12.09-10.15	■	
1.3 CDTi (A 13 DTE)		Diesel	FWD	1248	70	95	12.09-10.15	■	
ASTRA Mk VI (J) (P10) 06.12-							Saloon (Compact car-C Segment)		
1.4 Turbo (A 14 NET)		Gasolina	FWD	1364	103	140	06.12-10.15	■	

LISTA DE APLICACIONES - BUYERS GUIDE

1.4 (A 14 XER)		Gasolina	FWD	1398	74	101	06.12-10.15	■	
1.6 (A 16 XER)		Gasolina	FWD	1598	85	116	06.12-10.15	■	
1.3 CDTi (A 13 DTE)		Diesel	FWD	1248	70	95	06.12-10.15	■	
ASTRA Mk VI (J) GTC (P10) 10.11-						Hatchback (Compact car-C Segment)			
1.4 (A 14 NEL)		Gasolina	FWD	1364	88	120	10.11-10.18	■	
1.4 (B 14 NEL)		Gasolina	FWD	1364	88	120	10.11-10.18	■	
1.4 (A 14 NET)		Gasolina	FWD	1364	103	140	10.11-04.18	■	
1.4 (B 14 NET)		Gasolina	FWD	1364	103	140	10.11-04.18	■	
1.4 (A 14 XER)		Gasolina	FWD	1398	74	101	10.11-10.18	■	