

LISTA DE APLICACIONES - BUYERS GUIDE

182194



8 424073 109477

Qty: 300

Weight: 3.015

O.E.M.	MAKE
006 420 93 20	MERCEDES-BENZ
008 420 09 20-oe	MERCEDES-BENZ

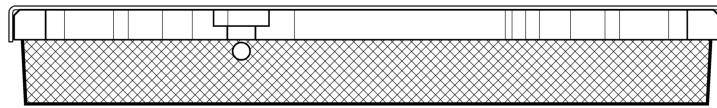
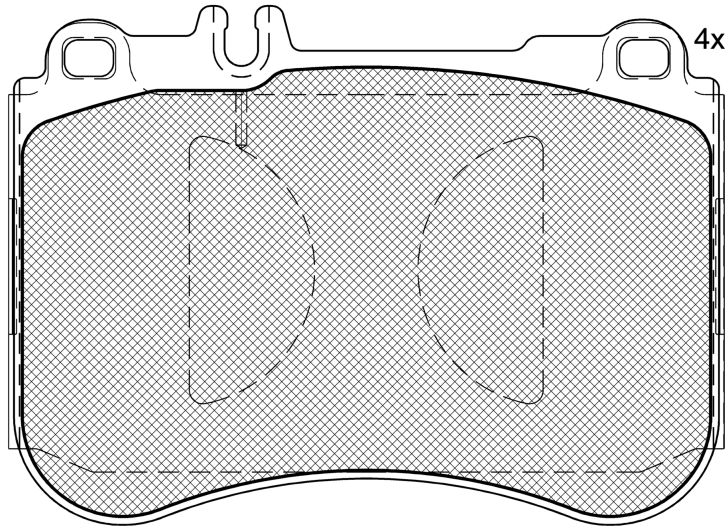

182194

E 9 90R-02A0111/4147



Brembo

131.4x95.3x18

WVA	FMSI
25179	D1782-8915
25705	
MAKE	
MERCEDES-BENZ	



Trac.	CC	Kw	CV



Front / Rear

MERCEDES-BENZ

S-Class VI (C217) 04.14-

Coupe (Luxury car-F Segment)

S500	Gasolina	FWD	3996	310	422	11.14-	■
S 500 4-matic (217.385) (M 278.929)	Rim 18, AMG Sports Package	Gasolina	4WD	4663	335	455 04.14-10.17	■
S 63 AMG 4-matic (217.378) (M 157.985)	Rim 18, AMG Sports Package	Gasolina	4WD	5461	430	585 04.14-10.17	■

S-Class VI (W222, V222, X222) 05.13-

Saloon (Luxury car-F Segment)

S 63 AMG (222.077, 222.177) (M 157.985)	Rim 18, AMG Sports Package	Gasolina	RWD	5461	430	585 05.13-05.17	■
S 63 AMG 4-matic (222.178) (M 157.985)	Rim 18, AMG Sports Package	Gasolina	4WD	5461	430	585 05.13-05.17	■