

LISTA DE APLICACIONES - BUYERS GUIDE

182205



8 424073 109705

Qty: 300

Weight: 1.205

O.E.M.	MAKE
04465-52170	SCION
04465-52210	SCION
04465-52220	TOYOTA
04465-52230	TOYOTA

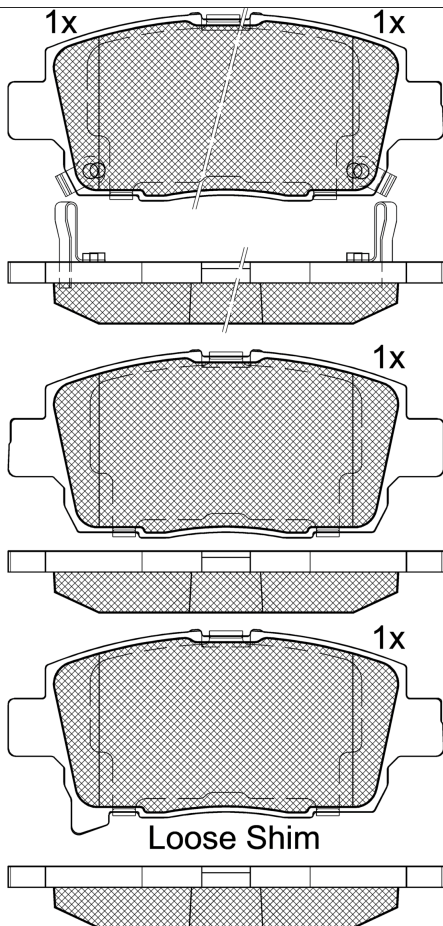

182205



90R-02A0111/4315

Akebono

116.4x50.3x17.1
116.4x54.9x17.1

WVA	FMSI
25316	D1249-8367
25317	
25318	
25319	
MAKE	
SCION	
TOYOTA	



Trac.	CC	Kw	CV		
				Front / Rear	

SCION									
xA 09.03-12.06							Hatchback (Supermini car-B Segment)		
1.5		Gasolina	FWD	1497	77	105	09.03-12.06	■	
1.5		Gasolina	FWD	1497	81	110	09.03-12.05	■	
xB 09.03-12.06							MPV (Compact car-C Segment)		
1.5 (1NZ-FE)	01/05-	Gasolina	FWD	1497	81	110	09.03-12.06	■	
TOYOTA									
bB (NCP3_) 01.00-12.05							MPV (Compact MPV-M1 Segment)		
1.3	-12/07	Gasolina	FWD	1298	68	92	12.05-	■	
1.3 (QNC20) (K3-VE)	-12/07	Gasolina	FWD	1298	68	92	12.05-06.16	■	
1.3 (NCP30_, NCP30) (2NZ-FE)	01/05-	Gasolina	FWD	1299	57	78	01.00-11.05	■	
1.3 (NCP30_)	11/04-	Gasolina	FWD	1299	64	87	01.00-11.05	■	
1.5 (QNC21) (3SZ-VE)	-12/07	Gasolina	FWD	1495	80	109	01.06-06.16	■	
1.5 4WD (NCP35) (1NZ-FE)		Gasolina	4WD	1497	77	105	03.00-12.05	■	
1.5 (NCP31) (1NZ-FE)	01/05-, for ESP	Gasolina	FWD	1497	80	109	03.00-12.05	■	
IST / XA (NCP6_) 04.02-07.07							Hatchback (Supermini car-B Segment)		
1.3 VVTi (NCP60) (2NZ-FE)	01/05-	Gasolina	FWD	1299	63	86	05.04-07.07	■	
1.5 VVTi (NCP61_, NCP61) (1NZ-FE)	01/05-	Gasolina	FWD	1497	80	109	05.04-07.07	■	
PORTE (_NNP1_) 07.04-07.12							Hatchback (Mini MPV-M1 Segment)		
1.3 VVTi (NNP10) (2NZ-FE)		Gasolina	FWD	1298	64	86	07.04-07.12	■	
1.5 4WD (NNP15) (1NZ-FE)		Gasolina	4WD	1497	77	105	07.04-07.12	■	
1.5 VVTi (NNP11) (1NZ-FE)		Gasolina	FWD	1497	81	110	07.04-07.12	■	

LISTA DE APLICACIONES - BUYERS GUIDE

PROBOX/SUCCEED (_P5_) 07.02-						Estate (Van-M2-Segment)			
1.5 VVTi 4WD (NCP59G) (1NZ-FE)	01/05-, Eq.V_ TX/F	Gasolina	4WD	1497	77	105	07.02-08.14	■	
1.5 VVTi (NCP58G) (1NZ-FE)	01/05-, Eq.V_ TX/F	Gasolina	FWD	1497	80	109	07.02-08.14	■	
RAUM II (NCZ2_) 05.03-						MPV (Large MPV-M1 Segment)			
1.5 4WD (NCZ25) (1NZ-FE)		Gasolina	4WD	1497	77	105	05.03-10.11	■	
1.5 (NCZ20) (1NZ-FE)		Gasolina	FWD	1497	80	109	05.03-10.11	■	
SIENTA (_P8_) 05.03-05.15						MPV (Mini MPV-M1 Segment)			
1.5	10/04-	Gasolina	FWD	1497	77	105	05.03-05.15	■	
1.5	10/04-	Gasolina	FWD	1497	77	105	05.03-05.15	■	
1.5 (NCP81)	10/04-	Gasolina	FWD	1497	81	110	05.03-05.15	■	
1.5 4WD (NCP85)	10/04-	Gasolina	4WD	1497	81	110	05.03-05.15	■	
YARIS VERSO / ECHO VERSO / FUN CARGO (_P2_) 03.00-09.05						Hatchback Van (Mini MPV-M1 Segment)			
1.3 VVTi (NCP22_) (2NZ-FE)		Gasolina	FWD	1299	62	84	04.03-09.05	■	
1.3 VVTi (NCP22_) (2NZ-FE)		Gasolina	FWD	1299	63	86	03.00-09.05	■	
1.5 VVTi (NCP21_) (1NZ-FE)		Gasolina	FWD	1497	78	106	03.00-03.03	■	
1.4 D4d (NLP22_) (1ND-TV)		Diesel	FWD	1364	55	75	10.01-09.05	■	
YARIS VERSO / ECHO VERSO / FUN CARGO (_P2_) 08.99-09.05						MPV (Mini MPV-M1 Segment)			
1.3 (NCP20_, NCP22_, NCP20R, NCP22R) (2NZ-FE)		Gasolina	FWD	1299	62	84	11.02-09.05	■	
1.3 (NCP20_, NCP22_, NCP20R, NCP22R) (2NZ-FE)		Gasolina	FWD	1299	63	86	08.99-10.02	■	
1.5 (NCP21_) (1NZ-FE)		Gasolina	FWD	1497	77	105	03.00-09.05	■	
1.5 (NCP21_) (1NZ-FE)		Gasolina	FWD	1497	78	106	03.00-09.05	■	
1.5 4WD (NCP25) (1NZ-FE)		Gasolina	4WD	1497	78	106	03.00-09.05	■	
1.5 (NCP21)		Gasolina	FWD	1497	80	109	08.02-09.05	■	
1.5 (NCP21)		Gasolina	FWD	1497	81	110	01.00-07.02	■	
1.4 D-4D (NLP20_, NLP22_) (1ND-TV)		Diesel	FWD	1364	55	75	09.00-09.05	■	