

# LISTA DE APLICACIONES - BUYERS GUIDE

## 182435



8 424073 207289

Qty: 300

Weight: 1.350

O.E.M.	MAKE
04465-K0000	TOYOTA
04465-K0010	TOYOTA
1M00-22-23Z	MAZDA
1M03-33-23Z	MAZDA

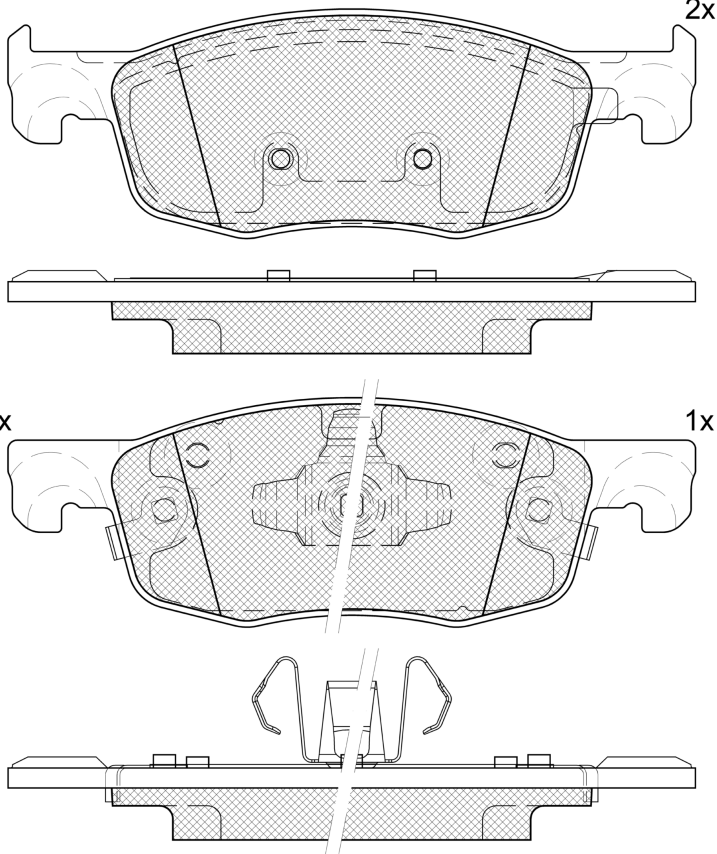

## 182435

E 9 90R-02A0111/5637



Ate - Teves

155.1x51.8x16.9

**WVA**

26444

26445

26446

**MAKE**

MAZDA

TOYOTA



Trac.	CC	Kw	CV
-------	----	----	----



Front / Rear

### MAZDA

							Hatchback (Supermini car-B Segment)	
<b>2 IV / DEMIO (KB) 03.22-</b>								
1.5 Hybrid (KBAC3X)		Gasol./el éc.	FWD	1490	68	92	03.22-	■
1.5 Hybrid (KBAC3X)		Gasol./el éc.	FWD	1490	85	116	03.22-	■

### TOYOTA

							Hatchback (City car-A Segment)	
<b>AYGO X ( _B7_ ) 03.22-</b>								
1.0 VVT-i (KGB70)		Gasolina	FWD	998	53	72	03.22-	■
							Hatchback (Supermini car-B Segment)	
<b>YARIS IV / VITZ ( _P21_ , _PA1_ , _PH1_ ) 02.20-</b>								
1.0 (KSP211) (1KR-FE)		Gasolina	FWD	998	53	72	02.20-	■
1.5 (MXPA10, MXPA11, MXPA12)		Gasolina	FWD	1490	88	120	02.20-	■
1.5 (MXPA11) (M15A-FKS)		Gasolina	FWD	1490	92	125	02.20-	■
1.5 Hybrid (MXPH11) (M15A-FXE)		Gasol./el éc.	FWD	1490	68	92	02.20-	■
1.5 Hybrid (MXPH10, MXPH11)		Gasol./el éc.	FWD	1490	85	116	02.20-	■
1.5 Hybrid (MXPH13, MXPH14)		Gasol./el éc.	FWD	1490	96	131	01.24-	■