

LISTA DE APLICACIONES - BUYERS GUIDE

182458



Qty: 300

Weight: 1.935

O.E.M.	MAKE
9V0 698 451 K	PORSCHE
9Y0 698 451	PORSCHE
9Y0 698 451 H	PORSCHE
9Y0 698 451 K	PORSCHE
9Y0 698 451 P	PORSCHE
9Y0698451AC	PORSCHE
9Y0698451M	PORSCHE

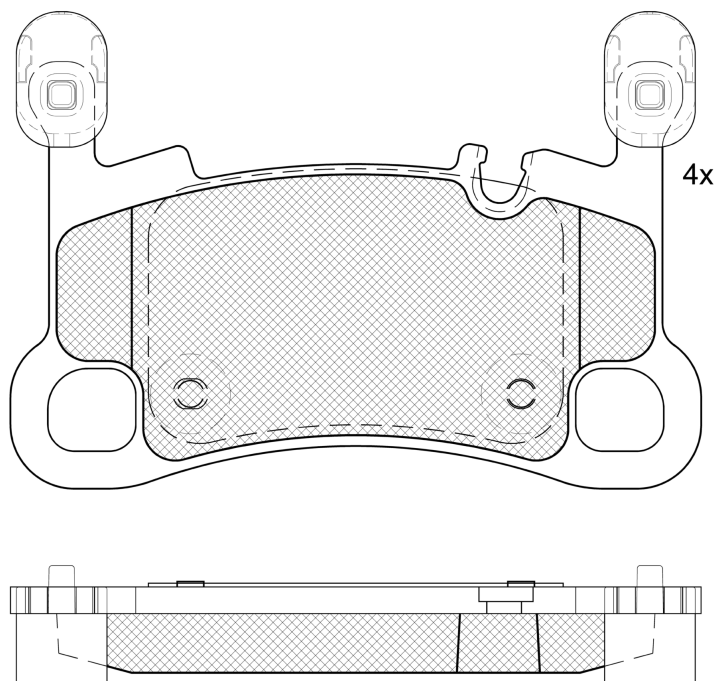

182458

E 9 90R-02A0111/5506



Brembo

129.6x80.1x16.8

WVA	FMSI
22468	D2166-9410
MAKE	
PORSCHE	



Trac.	CC	Kw	CV



Front / Rear

PORSCHE

CAYENNE III (9YA) 05.17-								SUV (Luxury Crossover SUV-J Segment)	
2.9 S AWD (9YABB1) (DCAB)		Gasolina	4WD	2894	324	441	05.17-05.23		■
2.9 S AWD (9YABB1) (MDC.AB)		Gasolina	4WD	2894	324	441	05.17-05.23		■
2.9 S AWD (9YBBB1) (DCAB)		Gasolina	4WD	2894	324	440	01.19-		■
3.0 AWD (9YAAA1) (DCBE)	PR 1KV, Syst. 18"	Gasolina	4WD	2995	250	340	05.17-05.23		■
3.0 AWD (9YAAA1) (MDC.BE)	PR 1KV, Syst. 18"	Gasolina	4WD	2995	250	340	05.17-05.23		■
3.0 AWD (9YBAA1) (DCBE)	PR 1KV, Syst. 18"	Gasolina	4WD	2995	250	340	01.19-		■
4.0 Turbo AWD (9YACF1) (DCUA)		Gasolina	4WD	3996	404	550	05.17-05.23		■
4.0 Turbo AWD (9YACF1) (MDC.UA)		Gasolina	4WD	3996	404	550	05.17-05.23		■
4.0 Turbo AWD (9YBCF1) (DCUA)		Gasolina	4WD	3996	404	550	01.19-		■
4.0 Turbo GT AWD (9YBCQ1)	PR 1KV, PR 1KR, Syst. 18"	Gasolina	4WD	3996	471	640	10.20-05.23		■
2.0 E-hybrid AWD (DFKA, EAL)	PR 1KR, Syst. 18"	Gasol./el éc.	4WD	1984	284	386	08.19-		■
2.0 E-Hybrid AWD (9YAAM1) (DFKA, EAL)	PR 1KR, Syst. 18"	Gasol./el éc.	4WD	1984	284	386	11.18-		■
3.0 E-Hybrid AWD (9YBDE1)	PR 1KR, Syst. 18"	Gasol./el éc.	4WD	2995	339	461	01.19-05.23		■
3.0 E-Hybrid AWD (9YAAE1) (DCBE)	PR 1KR, Syst. 18"	Gasol./el éc.	4WD	2995	340	462	05.17-05.23		■
4.0 Turbo S E-Hybrid AWD (9YBCH1)	PR 1KV, PR 1KR, Syst. 18"	Gasol./el éc.	4WD	3996	500	680	05.17-05.23		■