

LISTA DE APLICACIONES - BUYERS GUIDE

30858-9046

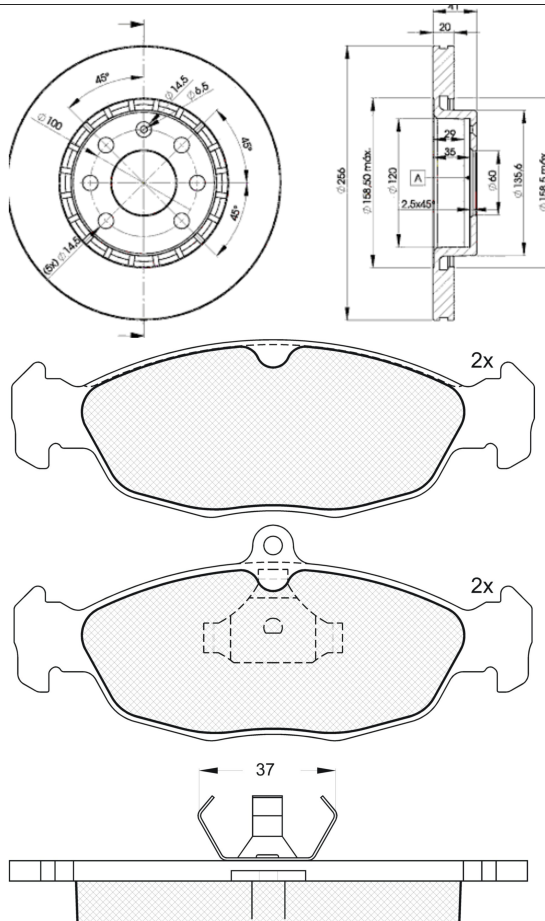

Weight: 11.890



30858-9046



Ate - Teves

140.1x58.3x16.8
Ø256x20x41

WVA
20547
MAKE
OPEL
VAUXHALL



Trac.	CC	Kw	CV
-------	----	----	----



Front / Rear

OPEL

								Estate (Compact car-C Segment)	
ASTRA F (T92) 09.91-01.01									
1.8 i (F35, M35) (C 18 NZ)	-12/94	Gasolina	FWD	1796	66	90	09.91-01.98	■	
1.8 i (F35, M35) (C 18 NZ)	-12/94	Gasolina	FWD	1796	66	90	09.91-01.98	■	
1.7 TDS (F35, M35) (17 TD)	01/95-	Diesel	FWD	1686	60	82	12.91-01.98	■	
1.7 TDS (F35, M35) (17 TD)	01/95-	Diesel	FWD	1686	60	82	12.91-01.98	■	
1.7 D (F35, M35) (17 D)		Diesel	FWD	1699	42	57	12.91-09.92	■	
1.7 D (F35, M35) (17 D)		Diesel	FWD	1699	42	57	12.91-09.92	■	
1.7 D (F35, M35) (17 DR)	01/93-	Diesel	FWD	1699	44	60	07.92-01.98	■	
1.7 D (F35, M35) (17 DR)	01/93-	Diesel	FWD	1699	44	60	07.92-01.98	■	
1.7 TD (F35, M35) (X 17 DTL)		Diesel	FWD	1699	50	68	11.94-01.98	■	
1.7 TD (F35, M35) (X 17 DTL)		Diesel	FWD	1699	50	68	11.94-01.98	■	
ASTRA F (T92) 09.91-10.00								Hatchback (Compact car-C Segment)	
1.8 i (F08, M08, F68, M68) (C 18 NZ)	-12/94	Gasolina	FWD	1796	66	90	09.91-01.98	■	
1.8 i (F08, M08, F68, M68) (C 18 NZ)	-12/94	Gasolina	FWD	1796	66	90	09.91-01.98	■	
ASTRA F (T92) 09.91-01.01								Saloon (Compact car-C Segment)	
1.8 i (F19, M19) (C 18 NZ)	-12/94	Gasolina	FWD	1796	66	90	03.92-09.98	■	
1.8 i (F19, M19) (C 18 NZ)	-12/94	Gasolina	FWD	1796	66	90	03.92-09.98	■	
CORSA B / VITA B (S93) 03.93-10.09								Hatchback (Supermini car-B Segment)	
1.6 i 16V (F08, F68, M68) (C 16 SEL)		Gasolina	FWD	1598	74	100	08.97-09.00	■	
1.6 i 16V (F08, F68, M68) (C 16 SEL)		Gasolina	FWD	1598	74	100	08.97-09.00	■	
1.6 i 16V (F08, F68, M68) (X 16 XE)		Gasolina	FWD	1598	78	106	09.94-09.00	■	
1.6 i 16V (F08, F68, M68) (X 16 XE)		Gasolina	FWD	1598	78	106	09.94-09.00	■	

LISTA DE APLICACIONES - BUYERS GUIDE

1.6 GSI 16V (F08, F68, M68) (C 16 XE)		Gasolina	FWD	1598	80	109	03.93-09.00	■	
1.6 GSI 16V (F08, F68, M68) (C 16 XE)		Gasolina	FWD	1598	80	109	03.93-09.00	■	
TIGRA A (S93) 07.94-12.00					Coupe (Sports car-S Segment)				
1.6 16V (F07) (C 16 SEL)		Gasolina	FWD	1598	74	100	08.97-08.98	■	
1.6 16V (F07) (C 16 SEL)		Gasolina	FWD	1598	74	100	08.97-08.98	■	
1.6 16V (F07) (X 16 XE)		Gasolina	FWD	1598	78	106	07.94-08.98	■	
1.6 16V (F07) (X 16 XE)		Gasolina	FWD	1598	78	106	07.94-08.98	■	
VECTRA A (J89) 04.88-12.95					Hatchback (Large family car-D Segment)				
1.7 TD (F68, M68) (17 TD)	01/91-	Diesel	FWD	1686	60	82	03.90-11.95	■	
1.7 TD (F68, M68) (17 TD)	01/91-	Diesel	FWD	1686	60	82	03.90-11.95	■	
1.7 D (F68, M68) (17 D)	01/92-	Diesel	FWD	1699	42	57	09.88-09.92	■	
1.7 D (F68, M68) (17 D)	01/92-	Diesel	FWD	1699	42	57	09.88-09.92	■	
VECTRA A (J89) 08.88-12.95					Saloon (Large family car-D Segment)				
1.7 TD (F19, M19) (17 TD)	01/91-	Diesel	FWD	1686	60	82	03.90-11.95	■	
1.7 TD (F19, M19) (17 TD)	01/91-	Diesel	FWD	1686	60	82	03.90-11.95	■	
1.7 D (F19, M19) (17 D)	01/92-	Diesel	FWD	1699	42	57	10.88-09.92	■	
1.7 D (F19, M19) (17 D)	01/92-	Diesel	FWD	1699	42	57	10.88-09.92	■	
VAUXHALL									
ASTRA Mk III (F) (T92) 03.91-12.98					Estate (Compact car-C Segment)				
1.8 i (C 18 NZ)	01/92-	Gasolina	FWD	1796	66	90	09.91-02.98	■	
1.8 i (C 18 NZ)	01/92-	Gasolina	FWD	1796	66	90	09.91-02.98	■	
ASTRA Mk III (F) (T92) 09.91-02.98					Hatchback (Compact car-C Segment)				
1.8 i (C 18 NZ)	-12/94	Gasolina	FWD	1796	66	90	09.91-02.98	■	
1.8 i (C 18 NZ)	-12/94	Gasolina	FWD	1796	66	90	09.91-02.98	■	
ASTRA Mk III (F) (T92) 09.91-09.98					Saloon (Compact car-C Segment)				
1.8 i (C 18 NZ)	-12/94	Gasolina	FWD	1796	66	90	03.92-09.98	■	
1.8 i (C 18 NZ)	-12/94	Gasolina	FWD	1796	66	90	03.92-09.98	■	
CAVALIER Mk III (J89) 08.88-11.95					Saloon (Large family car-D Segment)				
1.7 TD (17 TD)	01/91-	Diesel	FWD	1686	60	82	09.88-11.95	■	
1.7 TD (17 TD)	01/91-	Diesel	FWD	1686	60	82	09.88-11.95	■	
1.7 D (17 D)	01/91-	Diesel	FWD	1699	42	57	09.88-09.92	■	
1.7 D (17 D)	01/91-	Diesel	FWD	1699	42	57	09.88-09.92	■	
1.7 D (17 DR)		Diesel	FWD	1699	44	60	07.92-11.95	■	
1.7 D (17 DR)		Diesel	FWD	1699	44	60	07.92-11.95	■	
CAVALIER Mk III CC (J89) 09.88-11.95					Hatchback (Large family car-D Segment)				
1.8 i Cat (18 SV)	01/91-	Gasolina	FWD	1796	66	90	03.90-11.95	■	
1.8 i Cat (18 SV)	01/91-	Gasolina	FWD	1796	66	90	03.90-11.95	■	
1.8 i Cat (C 18 NZ)	01/91-	Gasolina	FWD	1796	66	90	03.90-11.95	■	
1.8 i Cat (C 18 NZ)	01/91-	Gasolina	FWD	1796	66	90	03.90-11.95	■	
1.7 TD (17 TD)	01/91-	Diesel	FWD	1686	60	82	09.88-11.95	■	
1.7 TD (17 TD)	01/91-	Diesel	FWD	1686	60	82	09.88-11.95	■	
1.7 D (17 DR)		Diesel	FWD	1699	44	60	07.92-11.95	■	
1.7 D (17 DR)		Diesel	FWD	1699	44	60	07.92-11.95	■	
CORSA Mk I (B) (S93) 12.92-09.00					Hatchback (Supermini car-B Segment)				
1.6 GSI 16V (C 16 XE)		Gasolina	FWD	1598	80	109	03.93-09.00	■	
1.6 GSI 16V (C 16 XE)		Gasolina	FWD	1598	80	109	03.93-09.00	■	

LISTA DE APLICACIONES - BUYERS GUIDE

TIGRA MK I (S93) 07.94-12.00				Coupe (Sports car-S Segment)			
1.6 16V (X 16 XE)	Gasolina	FWD	1598	78	106	07.94-12.00	■
1.6 16V (X 16 XE)	Gasolina	FWD	1598	78	106	07.94-12.00	■