

# LISTA DE APLICACIONES - BUYERS GUIDE

## 31450-4692

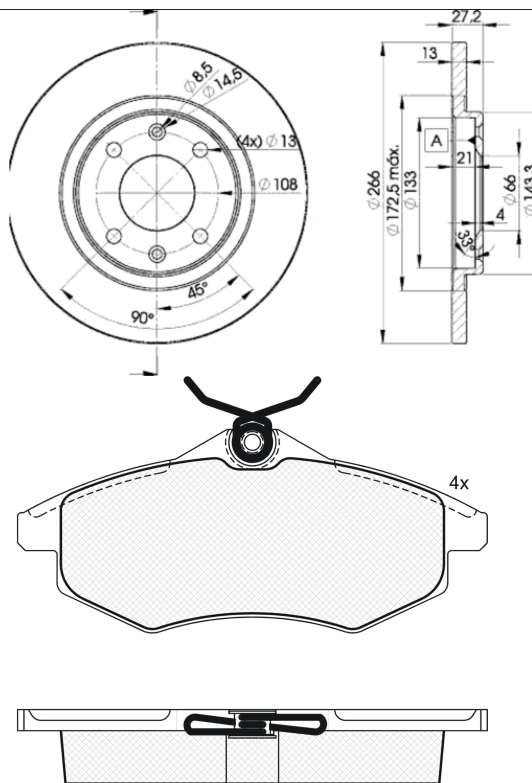

Weight: 10.938



**181450-700**

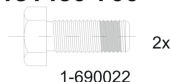

## 31450-4692



Lucas - Girling

122.6x53.2x19.3

Ø266x13x27

**WVA**

23407

**MAKE**

CITROËN



Trac.	CC	Kw	CV
-------	----	----	----



Front / Rear

### CITROËN

								Hatchback (Supermini car-B Segment)	
<b>C2 (JM_) 07.03-09.17</b>									
1.1 (HFX (TU1A))	-12/10	Gasolina	FWD	1124	44	60	09.03-09.12	■	
1.1 (HFX (TU1A))	-12/10	Gasolina	FWD	1124	44	60	09.03-09.12	■	
1.1 (HFX (TU1JP))	-12/10	Gasolina	FWD	1124	44	60	09.03-09.12	■	
1.1 (HFX (TU1JP))	-12/10	Gasolina	FWD	1124	44	60	09.03-09.12	■	
1.4 (KFV (TU3A))		Gasolina	FWD	1360	54	73	09.03-12.09	■	
1.4 (KFV (TU3A))		Gasolina	FWD	1360	54	73	09.03-12.09	■	
1.4 (KFV (TU3JP))		Gasolina	FWD	1360	54	73	09.03-12.09	■	
1.4 (KFV (TU3JP))		Gasolina	FWD	1360	54	73	09.03-12.09	■	
1.4 16V (KFU (ET3J4))		Gasolina	FWD	1360	65	90	04.05-12.09	■	
1.4 16V (KFU (ET3J4))		Gasolina	FWD	1360	65	90	04.05-12.09	■	
1.4 HDi (8HX (DV4TD))		Diesel	FWD	1398	50	68	07.03-12.09	■	
1.4 HDi (8HX (DV4TD))		Diesel	FWD	1398	50	68	07.03-12.09	■	
1.4 HDi (8HZ (DV4TD))		Diesel	FWD	1398	50	68	07.03-12.09	■	
1.4 HDi (8HZ (DV4TD))		Diesel	FWD	1398	50	68	07.03-12.09	■	
<b>C3 (FC_, FN_) 02.02-</b>									
								Hatchback (Supermini car-B Segment)	
1.1 i (HFX (TU1A))	-12/09	Gasolina	FWD	1124	44	60	02.02-12.09	■	
1.1 i (HFX (TU1A))	-12/09	Gasolina	FWD	1124	44	60	02.02-12.09	■	
1.1 i (HFX (TU1JP))	-12/09	Gasolina	FWD	1124	44	60	02.02-12.09	■	
1.1 i (HFX (TU1JP))	-12/09	Gasolina	FWD	1124	44	60	02.02-12.09	■	
1.4 i (KFV (TU3A))	-12/09	Gasolina	FWD	1360	54	73	02.02-11.10	■	
1.4 i (KFV (TU3A))	-12/09	Gasolina	FWD	1360	54	73	02.02-11.10	■	
1.4 i (KFV (TU3JP))	-12/09	Gasolina	FWD	1360	54	73	02.02-11.10	■	

## LISTA DE APLICACIONES - BUYERS GUIDE

1.4 i (KFV (TU3JP))	-12/09	Gasolina	FWD	1360	54	73	02.02-11.10	■
1.4 i		Gasolina	FWD	1360	55	75	07.03-02.12	■
1.4 i		Gasolina	FWD	1360	55	75	07.03-02.12	■
1.4 i Bivalent (KFV (TU3JP))	-12/09	Gasol./Gas (CNG)	FWD	1360	54	73	02.02-12.09	■
1.4 i Bivalent (KFV (TU3JP))	-12/09	Gasol./Gas (CNG)	FWD	1360	54	73	02.02-12.09	■
1.4 HDi (8HX (DV4TD))	-12/09	Diesel	FWD	1398	50	68	02.02-12.09	■
1.4 HDi (8HX (DV4TD))	-12/09	Diesel	FWD	1398	50	68	02.02-12.09	■
1.4 HDi (8HZ (DV4TD))	-12/09	Diesel	FWD	1398	50	68	02.02-12.09	■
1.4 HDi (8HZ (DV4TD))	-12/09	Diesel	FWD	1398	50	68	02.02-12.09	■
						<b>Hatchback (Supermini car-B Segment)</b>		
<b>C3 II (SC_) 09.09-</b>								
1.1 i (HFV (TU1A))		Gasolina	FWD	1124	44	60	09.09-01.13	■
1.1 i (HFV (TU1A))		Gasolina	FWD	1124	44	60	09.09-01.13	■
1.1 i (HFX (TU1A))		Gasolina	FWD	1124	44	60	09.09-01.13	■
1.1 i (HFX (TU1A))		Gasolina	FWD	1124	44	60	09.09-01.13	■
1.4 (K6E (TU3A))		Gasolina	FWD	1360	54	73	11.09-09.16	■
1.4 (K6E (TU3A))		Gasolina	FWD	1360	54	73	11.09-09.16	■
1.4 (KFT (TU3AE5))		Gasolina	FWD	1360	54	73	11.09-09.16	■
1.4 (KFT (TU3AE5))		Gasolina	FWD	1360	54	73	11.09-09.16	■
1.1 BiFuel (HFX (TU1A))		Gasol./Gas (LPG)	FWD	1124	44	60	11.10-09.16	■
1.1 BiFuel (HFX (TU1A))		Gasol./Gas (LPG)	FWD	1124	44	60	11.10-09.16	■