

LISTA DE APLICACIONES - BUYERS GUIDE

31587-2040

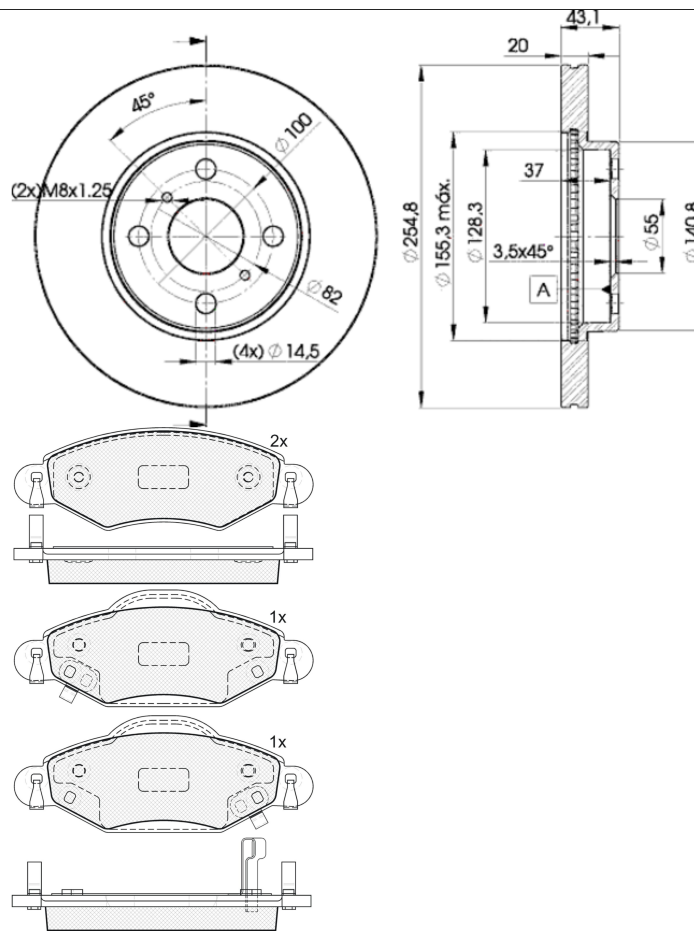

Weight: 11.691



31587-2040



Bosch

130.6x44.9x16.8
Ø255x20x43.4

WVA
23340
MAKE
TOYOTA



| Trac. | CC | Kw | CV |
|-------|----|----|----|
|-------|----|----|----|



Front / Rear

TOYOTA

| YARIS / ECHO / VITZ (_P1_) 01.99-12.05 | | | | | | | Hatchback (Supermini car-B Segment) | | |
|---|--------|----------|-----|------|-----|-----|-------------------------------------|---|--|
| 1.0 (SCP10_, SCP10R) (1SZ-FE) | | Gasolina | FWD | 998 | 48 | 65 | 03.03-09.05 | ■ | |
| 1.0 (SCP10_, SCP10R) (1SZ-FE) | | Gasolina | FWD | 998 | 48 | 65 | 03.03-09.05 | ■ | |
| 1.0 (SCP10_, SCP10R) (1SZ-FE) | 01/01- | Gasolina | FWD | 998 | 50 | 68 | 04.99-09.05 | ■ | |
| 1.0 (SCP10_, SCP10R) (1SZ-FE) | 01/01- | Gasolina | FWD | 998 | 50 | 68 | 04.99-09.05 | ■ | |
| 1.5 (NCP13_, NCP13R) (1NZ-FE) | | Gasolina | FWD | 1497 | 110 | 150 | 03.00-07.05 | ■ | |
| 1.5 (NCP13_, NCP13R) (1NZ-FE) | | Gasolina | FWD | 1497 | 110 | 150 | 03.00-07.05 | ■ | |
| 1.4 D-4D (NLP10_, NLP10R) (1ND-TV) | 01/03- | Diesel | FWD | 1364 | 55 | 75 | 10.01-09.05 | ■ | |
| 1.4 D-4D (NLP10_, NLP10R) (1ND-TV) | 01/03- | Diesel | FWD | 1364 | 55 | 75 | 10.01-09.05 | ■ | |