

LISTA DE APLICACIONES - BUYERS GUIDE

31592-9060

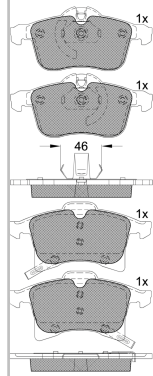

Weight: 16.323

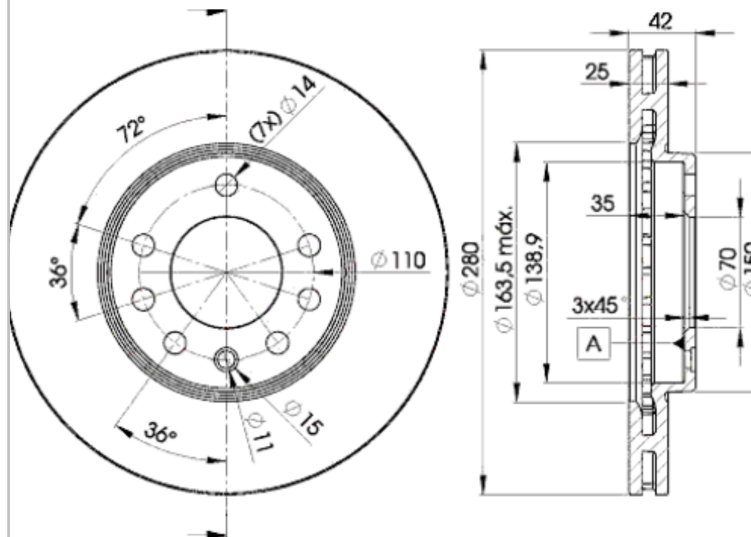

31592-9060



Ate - Teves

154.9x69.76x20.4
Ø280x25x42

WVA
23832

MAKE
OPEL
VAUXHALL



Trac.	CC	Kw	CV
-------	----	----	----



Front / Rear

OPEL

ASTRA H (A04) 08.04-10.10

Estate (Compact car-C Segment)

Model	Year	Fuel	Trac.	CC	Kw	CV	Period	Application
1.6 (L35) (A 16 XER)	-12/09	Gasolina	FWD	1598	85	116	11.06-10.10	■
1.6 (L35) (A 16 XER)	-12/09	Gasolina	FWD	1598	85	116	11.06-10.10	■
1.6 (L35) (Z 16 XER)	-12/09	Gasolina	FWD	1598	85	116	11.06-10.10	■
1.6 (L35) (Z 16 XER)	-12/09	Gasolina	FWD	1598	85	116	11.06-10.10	■
1.8 (L35) (Z 18 XE)	-12/09	Gasolina	FWD	1796	92	125	08.04-10.10	■
1.8 (L35) (Z 18 XE)	-12/09	Gasolina	FWD	1796	92	125	08.04-10.10	■
1.8 (L35) (A 18 XER)	-12/09	Gasolina	FWD	1796	103	140	11.05-10.10	■
1.8 (L35) (A 18 XER)	-12/09	Gasolina	FWD	1796	103	140	11.05-10.10	■
1.8 (L35) (Z 18 XER)	-12/09	Gasolina	FWD	1796	103	140	11.05-10.10	■
1.8 (L35) (Z 18 XER)	-12/09	Gasolina	FWD	1796	103	140	11.05-10.10	■
1.3 CDTI (L35) (Z 13 DTH)	-12/09	Diesel	FWD	1248	66	90	08.05-10.10	■
1.3 CDTI (L35) (Z 13 DTH)	-12/09	Diesel	FWD	1248	66	90	08.05-10.10	■
1.7 CDTI (L35) (Z 17 DTL)	-12/09	Diesel	FWD	1686	59	80	08.04-10.10	■
1.7 CDTI (L35) (Z 17 DTL)	-12/09	Diesel	FWD	1686	59	80	08.04-10.10	■
1.7 CDTI (L35) (Z 17 DTH)	-12/09	Diesel	FWD	1686	74	101	08.04-10.10	■
1.7 CDTI (L35) (Z 17 DTH)	-12/09	Diesel	FWD	1686	74	101	08.04-10.10	■
1.7 CDTI (L35) (A 17 DTJ)	-12/09	Diesel	FWD	1686	81	110	12.08-10.10	■
1.7 CDTI (L35) (A 17 DTJ)	-12/09	Diesel	FWD	1686	81	110	12.08-10.10	■
1.7 CDTI (L35) (Z 17 DTJ)	-12/09	Diesel	FWD	1686	81	110	12.08-10.10	■
1.7 CDTI (L35) (Z 17 DTJ)	-12/09	Diesel	FWD	1686	81	110	12.08-10.10	■

ASTRA H (A04) 01.04-01.11

Hatchback (Compact car-C Segment)

1.8 (L48) (Z 18 XE)	-12/09	Gasolina	FWD	1796	92	125	01.04-10.10	■
---------------------	--------	----------	-----	------	----	-----	-------------	---

LISTA DE APLICACIONES - BUYERS GUIDE

1.8 (L48) (Z 18 XE)	-12/09	Gasolina	FWD	1796	92	125	01.04-10.10	■
1.8 (L48) (A 18 XER)	-12/09	Gasolina	FWD	1796	103	140	01.06-10.10	■
1.8 (L48) (A 18 XER)	-12/09	Gasolina	FWD	1796	103	140	01.06-10.10	■
1.8 (L48) (Z 18 XER)	-12/09	Gasolina	FWD	1796	103	140	01.06-10.10	■
1.8 (L48) (Z 18 XER)	-12/09	Gasolina	FWD	1796	103	140	01.06-10.10	■
1.3 CDTI (L48) (Z 13 DTH)	-12/09	Diesel	FWD	1248	66	90	08.05-10.10	■
1.3 CDTI (L48) (Z 13 DTH)	-12/09	Diesel	FWD	1248	66	90	08.05-10.10	■
1.7 CDTI (L48) (Z 17 DTL)	-12/09	Diesel	FWD	1686	59	80	03.04-10.10	■
1.7 CDTI (L48) (Z 17 DTL)	-12/09	Diesel	FWD	1686	59	80	03.04-10.10	■
1.7 CDTI (L48) (Z 17 DTH)	-12/09	Diesel	FWD	1686	74	100	03.04-10.10	■
1.7 CDTI (L48) (Z 17 DTH)	-12/09	Diesel	FWD	1686	74	100	03.04-10.10	■
1.7 CDTI (L48) (A 17 DTJ)	-12/09	Diesel	FWD	1686	81	110	04.07-09.09	■
1.7 CDTI (L48) (A 17 DTJ)	-12/09	Diesel	FWD	1686	81	110	04.07-09.09	■
1.7 CDTI (L48) (Z 17 DTJ)	-12/09	Diesel	FWD	1686	81	110	04.07-09.09	■
1.7 CDTI (L48) (Z 17 DTJ)	-12/09	Diesel	FWD	1686	81	110	04.07-09.09	■
1.7 CDTI (L48) (Z 17 DTJ)	-12/09	Diesel	FWD	1686	81	110	04.07-09.09	■
1.9 CDTI (L48) (Z 19 DTL)	-12/09	Diesel	FWD	1910	74	100	09.05-10.10	■
1.9 CDTI (L48) (Z 19 DTL)	-12/09	Diesel	FWD	1910	74	100	09.05-10.10	■
ASTRA H (A04) 02.07-12.13						Saloon (Compact car-C Segment)		
1.7 CDTi (L69) (Z 17 DTH)	-12/09	Diesel	FWD	1686	74	101	02.07-10.10	■
1.7 CDTi (L69) (Z 17 DTH)	-12/09	Diesel	FWD	1686	74	101	02.07-10.10	■
ASTRA H CLASSIC (A04) 01.09-						Hatchback (Compact car-C Segment)		
1.3 CDTI (L48) (Z 13 DTH)		Diesel	FWD	1248	66	90	01.09-05.14	■
1.3 CDTI (L48) (Z 13 DTH)		Diesel	FWD	1248	66	90	01.09-05.14	■
ASTRA H GTC (A04) 03.05-10.10						Hatchback (Compact car-C Segment)		
1.8 (L08) (Z 18 XE)	-12/09	Gasolina	FWD	1796	92	125	03.05-10.10	■
1.8 (L08) (Z 18 XE)	-12/09	Gasolina	FWD	1796	92	125	03.05-10.10	■
1.8 (L08) (Z 18 XER)	-12/09	Gasolina	FWD	1796	103	140	01.06-10.10	■
1.8 (L08) (Z 18 XER)	-12/09	Gasolina	FWD	1796	103	140	01.06-10.10	■
1.3 CDTI (L08) (Z 13 DTH)	-12/09	Diesel	FWD	1248	66	90	04.05-10.10	■
1.3 CDTI (L08) (Z 13 DTH)	-12/09	Diesel	FWD	1248	66	90	04.05-10.10	■
1.7 CDTi (L08) (Z 17 DTL)	-12/09	Diesel	FWD	1686	59	80	03.05-10.10	■
1.7 CDTi (L08) (Z 17 DTL)	-12/09	Diesel	FWD	1686	59	80	03.05-10.10	■
1.7 CDTi (L08) (Z 17 DTH)	-12/09	Diesel	FWD	1686	74	101	03.05-10.10	■
1.7 CDTi (L08) (Z 17 DTH)	-12/09	Diesel	FWD	1686	74	101	03.05-10.10	■
1.7 CDTi (L08) (A 17 DTJ)	-12/09	Diesel	FWD	1686	81	110	02.07-10.10	■
1.7 CDTi (L08) (A 17 DTJ)	-12/09	Diesel	FWD	1686	81	110	02.07-10.10	■
1.7 CDTi (L08) (Z 17 DTJ)	-12/09	Diesel	FWD	1686	81	110	02.07-10.10	■
1.7 CDTi (L08) (Z 17 DTJ)	-12/09	Diesel	FWD	1686	81	110	02.07-10.10	■
ASTRA H TwinTop (A04) 09.05-12.13						Convertible (Compact car-C Segment)		
1.8 (L67) (Z 18 XE)	-12/09	Gasolina	FWD	1796	92	125	09.05-10.10	■
1.8 (L67) (Z 18 XE)	-12/09	Gasolina	FWD	1796	92	125	09.05-10.10	■
1.8 (L67) (A 18 XER)	-12/09	Gasolina	FWD	1796	103	140	09.05-10.10	■
1.8 (L67) (A 18 XER)	-12/09	Gasolina	FWD	1796	103	140	09.05-10.10	■
1.8 (L67) (Z 18 XER)	-12/09	Gasolina	FWD	1796	103	140	09.05-10.10	■
1.8 (L67) (Z 18 XER)	-12/09	Gasolina	FWD	1796	103	140	09.05-10.10	■
COMBO C 10.01-						Box Body/MPV (LCVs-N1 Segment)		
1.7 CDTI 16V (Z 17 DTH)		Diesel	FWD	1686	74	101	12.04-	■
1.7 CDTI 16V (Z 17 DTH)		Diesel	FWD	1686	74	101	12.04-	■

LISTA DE APLICACIONES - BUYERS GUIDE

COMBO C Tour 10.01-					MPV (Large MPV-M1 Segment)			
1.7 CDTI 16V (Z 17 DTH)		Diesel	FWD	1686	74	101	07.04-12.11	■
1.7 CDTI 16V (Z 17 DTH)		Diesel	FWD	1686	74	101	07.04-12.11	■
MERIVA A (X03) 05.03-05.10					MPV (Mini MPV-M1 Segment)			
1.7 CDTI (E75) (Z 17 DT)	-12/08	Diesel	FWD	1686	74	100	09.03-05.10	■
1.7 CDTI (E75) (Z 17 DT)	-12/08	Diesel	FWD	1686	74	100	09.03-05.10	■
1.7 CDTI (E75) (Z 17 DTH)	-12/08	Diesel	FWD	1686	74	100	09.03-05.10	■
1.7 CDTI (E75) (Z 17 DTH)	-12/08	Diesel	FWD	1686	74	100	09.03-05.10	■
1.7 CDTI (E75) (Z 17 DTR)	-12/08	Diesel	FWD	1686	92	125	09.06-05.10	■
1.7 CDTI (E75) (Z 17 DTR)	-12/08	Diesel	FWD	1686	92	125	09.06-05.10	■
ZAFIRA / ZAFIRA FAMILY B (A05) 07.05-					MPV (Compact MPV-M1 Segment)			
1.6 (M75) (Z 16 XE1)	-12/11	Gasolina	FWD	1598	77	105	07.05-09.12	■
1.6 (M75) (Z 16 XE1)	-12/11	Gasolina	FWD	1598	77	105	07.05-09.12	■
1.6 (M75) (Z 16 XEP)	-12/11	Gasolina	FWD	1598	77	105	07.05-09.12	■
1.6 (M75) (Z 16 XEP)	-12/11	Gasolina	FWD	1598	77	105	07.05-09.12	■
1.6 (M75) (A 16 XER)	-12/11	Gasolina	FWD	1598	85	115	01.08-04.15	■
1.6 (M75) (A 16 XER)	-12/11	Gasolina	FWD	1598	85	115	01.08-04.15	■
1.6 (M75) (Z 16 XER)	-12/11	Gasolina	FWD	1598	85	115	01.08-04.15	■
1.6 (M75) (Z 16 XER)	-12/11	Gasolina	FWD	1598	85	115	01.08-04.15	■
1.8 (M75) (A 18 XER)	-12/11	Gasolina	FWD	1796	103	140	07.05-04.15	■
1.8 (M75) (A 18 XER)	-12/11	Gasolina	FWD	1796	103	140	07.05-04.15	■
1.8 (M75) (Z 18 XER)	-12/11	Gasolina	FWD	1796	103	140	07.05-04.15	■
1.8 (M75) (Z 18 XER)	-12/11	Gasolina	FWD	1796	103	140	07.05-04.15	■
1.6 CNG (M75) (Z 16 YNG)	-12/11	Gasol./Gas (CNG)	FWD	1598	69	94	07.05-04.15	■
1.6 CNG (M75) (Z 16 YNG)	-12/11	Gasol./Gas (CNG)	FWD	1598	69	94	07.05-04.15	■
VAUXHALL								
ASTRA Mk V (H) (A04) 08.04-10.12					Estate (Compact car-C Segment)			
1.6 (L35) (A 16 LET)	01/06-	Gasolina	FWD	1598	132	180	08.04-03.09	■
1.6 (L35) (A 16 LET)	01/06-	Gasolina	FWD	1598	132	180	08.04-03.09	■
1.6 (L35) (Z 16 LET)	01/06-	Gasolina	FWD	1598	132	180	08.04-03.09	■
1.6 (L35) (Z 16 LET)	01/06-	Gasolina	FWD	1598	132	180	08.04-03.09	■
1.8 (L35) (Z 18 XE)		Gasolina	FWD	1796	92	125	10.04-03.09	■
1.8 (L35) (Z 18 XE)		Gasolina	FWD	1796	92	125	10.04-03.09	■
1.8 (L35) (A 18 XER)	01/08-	Gasolina	FWD	1796	103	140	12.05-10.10	■
1.8 (L35) (A 18 XER)	01/08-	Gasolina	FWD	1796	103	140	12.05-10.10	■
1.8 (L35) (Z 18 XER)	01/08-	Gasolina	FWD	1796	103	140	12.05-10.10	■
1.8 (L35) (Z 18 XER)	01/08-	Gasolina	FWD	1796	103	140	12.05-10.10	■
1.3 CDTI (L35) (Z 13 DTH)	01/05-	Diesel	FWD	1248	66	90	08.04-03.09	■
1.3 CDTI (L35) (Z 13 DTH)	01/05-	Diesel	FWD	1248	66	90	08.04-03.09	■
1.7 CDTI (L35) (Z 17 DTH)		Diesel	FWD	1686	74	100	08.04-03.09	■
1.7 CDTI (L35) (Z 17 DTH)		Diesel	FWD	1686	74	100	08.04-03.09	■
1.7 TD	01/08-	Diesel	RWD	1686	79	108	08.04-03.09	■
1.7 TD	01/08-	Diesel	RWD	1686	79	108	08.04-03.09	■
1.7 CDTI (L35) (A 17 DTJ)	01/07-	Diesel	FWD	1686	81	110	08.04-10.12	■
1.7 CDTI (L35) (A 17 DTJ)	01/07-	Diesel	FWD	1686	81	110	08.04-10.12	■
1.7 CDTI (L35) (Z 17 DTJ)	01/07-	Diesel	FWD	1686	81	110	08.04-10.12	■
1.7 CDTI (L35) (Z 17 DTJ)	01/07-	Diesel	FWD	1686	81	110	08.04-10.12	■

LISTA DE APLICACIONES - BUYERS GUIDE

ASTRA Mk V (H) (A04) 01.04-03.11					Hatchback (Compact car-C Segment)			
1.8 (L48) (Z 18 XE)		Gasolina	FWD	1796	92	125	01.04-05.09	■
1.8 (L48) (Z 18 XE)		Gasolina	FWD	1796	92	125	01.04-05.09	■
1.8 (L48) (A 18 XER)	01/06-	Gasolina	FWD	1796	103	140	01.04-05.09	■
1.8 (L48) (A 18 XER)	01/06-	Gasolina	FWD	1796	103	140	01.04-05.09	■
1.8 (L48) (Z 18 XER)	01/06-	Gasolina	FWD	1796	103	140	01.04-05.09	■
1.8 (L48) (Z 18 XER)	01/06-	Gasolina	FWD	1796	103	140	01.04-05.09	■
1.3 CDTI (L48) (Z 13 DTH)	01/05-	Diesel	FWD	1248	66	90	01.04-05.09	■
1.3 CDTI (L48) (Z 13 DTH)	01/05-	Diesel	FWD	1248	66	90	01.04-05.09	■
1.7 CDTI (L48) (Z 17 DTL)		Diesel	FWD	1686	59	80	01.04-05.09	■
1.7 CDTI (L48) (Z 17 DTL)		Diesel	FWD	1686	59	80	01.04-05.09	■
1.7 CDTI (L48) (Z 17 DTH)		Diesel	FWD	1686	74	100	01.04-05.09	■
1.7 CDTI (L48) (Z 17 DTH)		Diesel	FWD	1686	74	100	01.04-05.09	■
1.7 TD	01/08-	Diesel	RWD	1686	79	108	01.04-05.09	■
1.7 TD	01/08-	Diesel	RWD	1686	79	108	01.04-05.09	■
1.7 CDTI (L48) (A 17 DTJ)	01/07-	Diesel	FWD	1686	81	110	01.04-03.11	■
1.7 CDTI (L48) (A 17 DTJ)	01/07-	Diesel	FWD	1686	81	110	01.04-03.11	■
1.7 CDTI (L48) (Z 17 DTJ)	01/07-	Diesel	FWD	1686	81	110	01.04-03.11	■
1.7 CDTI (L48) (Z 17 DTJ)	01/07-	Diesel	FWD	1686	81	110	01.04-03.11	■
ASTRA Mk V (H) Sport Hatch (A04) 02.05-11.10					Hatchback (Compact car-C Segment)			
1.8 (L08) (Z 18 XE)	-12/09	Gasolina	FWD	1796	92	125	02.05-11.10	■
1.8 (L08) (Z 18 XE)	-12/09	Gasolina	FWD	1796	92	125	02.05-11.10	■
1.8 i 16V (L08) (A 18 XER)	-12/09	Gasolina	FWD	1796	103	140	03.07-11.10	■
1.8 i 16V (L08) (A 18 XER)	-12/09	Gasolina	FWD	1796	103	140	03.07-11.10	■
1.8 i 16V (L08) (Z 18 XER)	-12/09	Gasolina	FWD	1796	103	140	03.07-11.10	■
1.8 i 16V (L08) (Z 18 XER)	-12/09	Gasolina	FWD	1796	103	140	03.07-11.10	■
1.3 CDTI (L08) (Z 13 DTH)	-12/09	Diesel	FWD	1248	66	90	04.05-11.10	■
1.3 CDTI (L08) (Z 13 DTH)	-12/09	Diesel	FWD	1248	66	90	04.05-11.10	■
1.7 CDTi (L08) (Z 17 DTH)	-12/09	Diesel	FWD	1686	74	100	02.05-11.10	■
1.7 CDTi (L08) (Z 17 DTH)	-12/09	Diesel	FWD	1686	74	100	02.05-11.10	■
ASTRA Mk V (H) TwinTop (A04) 09.05-08.11					Convertible (Compact car-C Segment)			
1.6 (L67) (Z 16 XEP)	-12/09	Gasolina	FWD	1598	77	105	09.05-11.10	■
1.6 (L67) (Z 16 XEP)	-12/09	Gasolina	FWD	1598	77	105	09.05-11.10	■
1.6 i 16V (L67) (A 16 XER)	-12/09	Gasolina	FWD	1598	85	116	10.06-08.11	■
1.6 i 16V (L67) (A 16 XER)	-12/09	Gasolina	FWD	1598	85	116	10.06-08.11	■
1.6 i 16V (L67) (Z 16 XER)	-12/09	Gasolina	FWD	1598	85	116	10.06-08.11	■
1.6 i 16V (L67) (Z 16 XER)	-12/09	Gasolina	FWD	1598	85	116	10.06-08.11	■
1.6	-12/09	Gasolina	FWD	1598	132	179	10.06-11.10	■
1.6	-12/09	Gasolina	FWD	1598	132	179	10.06-11.10	■
1.8 (L67) (A 18 XER)	-12/09	Gasolina	FWD	1796	103	140	05.08-11.10	■
1.8 (L67) (A 18 XER)	-12/09	Gasolina	FWD	1796	103	140	05.08-11.10	■
1.8 (L67) (Z 18 XER)	-12/09	Gasolina	FWD	1796	103	140	05.08-11.10	■
1.8 (L67) (Z 18 XER)	-12/09	Gasolina	FWD	1796	103	140	05.08-11.10	■
MERIVA Mk I (A) (X03) 01.03-06.10					MPV (Mini MPV-M1 Segment)			
1.7 CDTi (Z 17 DTH)	01/04-	Diesel	FWD	1686	74	100	09.03-06.08	■
1.7 CDTi (Z 17 DTH)	01/04-	Diesel	FWD	1686	74	100	09.03-06.08	■
1.7 CDTi		Diesel	RWD	1686	92	125	08.06-06.10	■
1.7 CDTi		Diesel	RWD	1686	92	125	08.06-06.10	■

LISTA DE APLICACIONES - BUYERS GUIDE

ZAFIRA Mk II (B) (A05) 04.05-11.14					MPV (Compact MPV-M1 Segment)			
1.8 (A 18 XER)		Gasolina	FWD	1796	103	140	04.05-11.14	■
1.8 (A 18 XER)		Gasolina	FWD	1796	103	140	04.05-11.14	■
1.8 (Z 18 XER)		Gasolina	FWD	1796	103	140	04.05-11.14	■
1.8 (Z 18 XER)		Gasolina	FWD	1796	103	140	04.05-11.14	■