

LISTA DE APLICACIONES - BUYERS GUIDE

78BD0051-2



Weight: 12.260

O.E.M.	MAKE
435120D080	TOYOTA
435120D100	TOYOTA
435120D190	TOYOTA
435120D250	TOYOTA
4351252130	TOYOTA

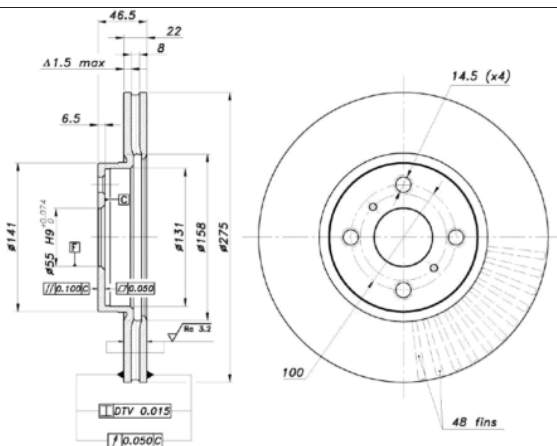

78BD0051-2



Ø275x22x46.5

MAKE
DAIHATSU
TOYOTA



Trac.	CC	Kw	CV	Hourglass icon	Front / Rear
-------	----	----	----	----------------	--------------

DAIHATSU

CHARADE VI 05.11-							Hatchback (Supermini car-B Segment)		
1.33 16V (1NR-FE)	vehicles with ABS	Gasolina	FWD	1329	73	99	05.11-	■	

TOYOTA

COROLLA X / ALTIS (_E15_) 10.06-							Saloon (Compact executive car-D Segment)		
1.5		Gasolina	FWD	1497	77	105	08.07-	■	
1.5		Gasolina	FWD	1497	81	110	08.07-	■	
1.8		Gasolina	FWD	1798	98	133	08.07-	■	

COROLLA X / FIELDER (_E14_) 09.06-							Estate (Compact executive car-D Segment)		
1.5 4WD (NZE144)		Gasolina	4WD	1497	77	105	09.06-04.12	■	
1.5 (NZE141)		Gasolina	FWD	1497	81	110	09.06-04.12	■	
1.8 (ZRE142)		Gasolina	FWD	1797	100	136	09.06-04.12	■	
1.8 4WD (ZRE144G)		Gasolina	4WD	1798	98	133	09.06-04.12	■	
1.8 (ZRE142G)		Gasolina	FWD	1798	106	144	09.06-04.12	■	

RACTIS (_P10_) 09.05-08.10							MPV (Mini MPV-M1 Segment)		
1.3 (SCP100_, SCP100) (2SZ-FE)		Gasolina	FWD	1298	64	87	09.05-08.10	■	
1.5 4WD (NCP105_, NCP105) (1NZ-FE)		Gasolina	4WD	1497	77	105	09.05-08.10	■	
1.5 (NCP100_, NCP100) (1NZ-FE)		Gasolina	FWD	1497	81	110	09.05-08.10	■	

YARIS II / VITZ (_P9_) 01.05-							Hatchback (Supermini car-B Segment)		
1.8 VVTi		Gasolina	FWD	1794	97	132	11.05-	■	
1.8 VVTi (ZSP90_, ZSP90R) (2ZR-FE)		Gasolina	FWD	1798	98	133	01.07-12.11	■	

LISTA DE APLICACIONES - BUYERS GUIDE

					Hatchback Van (Supermini car-B Segment)			
YARIS III / VITZ (_P13_) 10.12-					73	99	10.12-03.17	■
1.3 VVTi (NSP130) (1NR-FE)		Gasolina	FWD	1329				
YARIS III / VITZ (_P13_) 12.10-					Hatchback (Supermini car-B Segment)			
1.2 (NSP152_)		Gasolina	FWD	1197	63	86	10.13-	■
1.3 (NCP151_, NCP151R) (2NZ-FE)		Gasolina	FWD	1299	63	86	10.13-09.16	■
1.3 (NSP130_, NSP130)		Gasolina	FWD	1329	70	95	12.10-07.14	■
1.3 (NSP130_, NSP130) (1NR-FE)		Gasolina	FWD	1329	73	99	09.11-03.17	■
1.3 (NSP130_, NSP130) (1NR-FKE)		Gasolina	FWD	1329	73	99	09.11-03.17	■
1.3 (NSP150_) (1NR-FE)		Gasolina	FWD	1329	73	99	04.16-	■
1.5 (NCP131_)	disc brak.rear axle	Gasolina	FWD	1497	79	107	09.11-	■
1.5 (NCP150_, NSP151_) (1NZ-FE)		Gasolina	FWD	1497	79	107	03.14-	■
1.5 (NCP150_, NSP151_) (2NR-FE)		Gasolina	FWD	1497	79	107	03.14-	■
1.5 (NCP150_) (1NZ-FE)		Gasolina	FWD	1497	80	109	03.14-	■
1.2 VVT-iE Flex (NSP152_) (3NR-FKE)		Gasol./Etanol	FWD	1197	68	92	11.19-	■
1.5 Hybrid (NHP130_, NHP130) (1NZ-FXE)		Gasol./eléc.	FWD	1497	74	101	03.12-06.20	■
YARIS III / VITZ (_P15_) 04.16-					Saloon (Supermini car-B Segment)			
1.2 (NSP152_) (3NR-FE)		Gasolina	FWD	1197	63	86	08.17-	■
1.2 VVT-iE Flex (NSP152_)		Gasol./Etanol	FWD	1197	68	92	11.19-	■
1.2 VVT-iE Flex (NSP152_) (3NR-FKE)		Gasol./Etanol	FWD	1197	68	92	11.19-	■
YARIS IV / VITZ (_P21_, _PA1_, _PH1_) 02.20-					Hatchback (Supermini car-B Segment)			
1.5 Hybrid (MXPH13, MXPH14)		Gasol./eléc.	FWD	1490	96	131	01.24-	■
YARIS / VIOS / BELTA (_P9_) 08.05-					Saloon (Supermini car-B Segment)			
1.3 (NCP92_, SCP92_, NCP92R) (2NZ-FE)	disc brak.rear axle	Gasolina	FWD	1298	64	87	09.05-10.13	■
1.3 (NCP92_, SCP92_, NCP92R) (2SZ-FE)	disc brak.rear axle	Gasolina	FWD	1298	64	87	09.05-10.13	■
1.3 4WD (NCP92_, NCP96_, NCP96R, NCP92R) (2NZ-FE)	disc brak.rear axle	Gasolina	4WD	1298	64	87	09.05-04.13	■
1.3 (NCP92_, NCP92R) (2NZ-FE)	disc brak.rear axle	Gasolina	FWD	1299	63	86	01.06-04.13	■
YARIS ATIV 08.17-08.22					Saloon (Supermini car-B Segment)			
1.2 VVT-iE (NSP152) (3NR-FKE)		Gasolina	FWD	1197	68	92	11.19-07.22	■
YARIS III / VIOS (_P15_) 05.13-					Saloon (Supermini car-B Segment)			
1.3 (NCP151_) (2NZ-FE)		Gasolina	FWD	1299	62	84	05.13-	■
1.3 (NCP151_) (2NZ-FE)		Gasolina	FWD	1299	63	86	05.13-	■
1.3 (NSP150_) (1NR-FE)		Gasolina	FWD	1329	62	84	10.17-	■
1.3 (NSP150_)		Gasolina	FWD	1329	72	98	04.16-	■
1.3 (NSP150_) (1NR-FE)		Gasolina	FWD	1329	73	99	04.16-	■
1.5 Dual VVT-i (NSP151_) (2NR-FBE)		Gasolina	FWD	1496	79	107	04.16-	■
1.5 Dual VVT-i (NSP151_) (2NR-FE)		Gasolina	FWD	1496	79	107	04.16-	■
1.5 (NCP150_) (1NZ-FE)		Gasolina	FWD	1497	79	107	05.13-	■
1.5 (NCP150_) (1NZ-FE)		Gasolina	FWD	1497	80	109	05.13-08.16	■