

# LISTA DE APLICACIONES - BUYERS GUIDE

## 78BD1553-2



Weight: 16.800

O.E.M.	MAKE
13515909	OPEL
13597467	OPEL

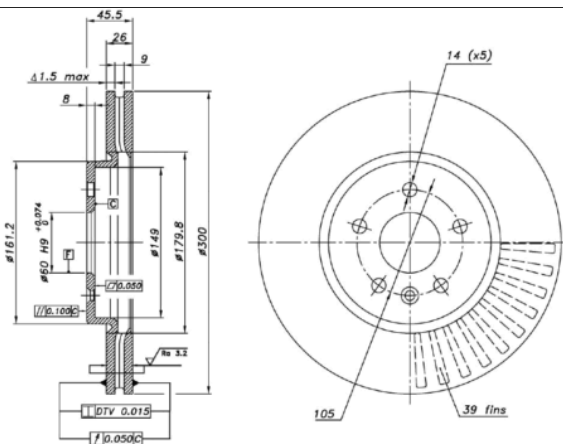

## 78BD1553-2



Ø300x26x45.5

MAKE
CHEVROLET
HOLDEN
OPEL
VAUXHALL



Trac.	CC	Kw	CV						
						Front / Rear			

### CHEVROLET

<b>CRUZE II (J405) 01.17-</b>						<b>Hatchback (Supermini car-B Segment)</b>			
1.4 (LE2(85CUL4))	Syst. 16"	Gasolina	FWD	1399	114	155	01.17-	■	
<b>CRUZE II (J400) 11.15-</b>						<b>Saloon (Supermini car-B Segment)</b>			
1.4 (LE2(85CUL4))	Syst. 16"	Gasolina	FWD	1399	114	155	11.15-	■	
1.4 Flex (LE2(85VUL4))	Syst. 16"	Gasol./Etanol	FWD	1399	113	153	01.17-	■	
CDTi (B 16 DTH)	Syst. 16"	Diesel	FWD	1598	99	135	11.15-	■	

### HOLDEN

<b>ASTRA (BK) 09.17-</b>						<b>Estate (Compact car-C Segment)</b>			
1.4 (B 14 XFT)	Syst. 16"	Gasolina	FWD	1399	110	150	09.17-	■	
<b>ASTRA (PJ) 12.14-</b>						<b>Hatchback (Compact car-C Segment)</b>			
1.4	Syst. 16"	Gasolina	FWD	1399	110	150	01.17-	■	
1.6 (B 16 SHT)	Syst. 16"	Gasolina	FWD	1598	147	200	09.16-	■	
<b>CALAIS (ZB) 10.17-</b>						<b>Hatchback (Luxury car-F Segment)</b>			
2.0 (LTG)		Gasolina	FWD	1998	191	260	10.17-10.20	■	
3.6 V6 (LGX)		Gasolina	4WD	3640	235	320	10.17-10.20	■	
2.0 D (LFS)		Diesel	FWD	1956	125	170	10.17-08.18	■	
<b>COMMODORE (ZB) 10.17-</b>						<b>Estate (Executive car-E Segment)</b>			
2.0		Gasolina	FWD	1998	191	260	10.17-	■	
3.6 V6		Gasolina	FWD	3640	235	320	10.17-	■	
<b>COMMODORE (ZB) 10.17-</b>						<b>Hatchback (Executive car-E Segment)</b>			
2.0		Gasolina	FWD	1998	191	260	10.17-	■	

# LISTA DE APLICACIONES - BUYERS GUIDE

3.6 V6		Gasolina	FWD	3640	235	320	10.17-	■	
2.0 D		Diesel	FWD	1956	125	170	10.17-	■	
2.0 D		Diesel	FWD	1956	125	170	10.17-	■	
<b>OPEL</b>									
<b>ASTRA K 11.15-</b>						<b>Estate Van (Compact car-C Segment)</b>			
1.0 (35) (D 10 XFL)		Gasolina	FWD	999	77	105	05.18-08.19	■	
1.4 (35) (D 14 XFT)		Gasolina	FWD	1399	110	150	06.18-09.21	■	
1.5 CRDI (35) (D 15 DVC)		Diesel	FWD	1496	77	105	08.19-09.21	■	
1.5 CRDI (35) (F 15 DVC)		Diesel	FWD	1496	77	105	08.19-09.21	■	
<b>ASTRA K 06.15-</b>						<b>Hatchback Van (Compact car-C Segment)</b>			
1.6 CDTi (D 16 DTH)		Diesel	FWD	1598	100	136	04.18-08.19	■	
<b>ASTRA K (B16) 06.15-</b>						<b>Hatchback (Compact car-C Segment)</b>			
1.0 Turbo (68) (D 10 XFL)		Gasolina	FWD	999	66	90	06.18-08.19	■	
1.0 Turbo (68) (B 10 XFL)		Gasolina	FWD	999	77	105	06.15-08.19	■	
1.0 Turbo (68) (D 10 XFL)		Gasolina	FWD	999	77	105	06.15-08.19	■	
1.2 Turbo (68) (F 12 SHL)		Gasolina	FWD	1199	81	110	08.19-09.21	■	
1.2 Turbo (68) (F 12 SHT)		Gasolina	FWD	1199	96	131	08.19-09.21	■	
1.2 Turbo (68) (F 12 SHR)		Gasolina	FWD	1199	107	145	08.19-09.21	■	
1.4 Turbo (68) (F 14 SHL)		Gasolina	FWD	1342	107	145	08.19-09.21	■	
1.4 Turbo (68) (F 14 SHT)		Gasolina	FWD	1342	107	145	08.19-09.21	■	
1.4 (68) (B 14 XE)		Gasolina	FWD	1399	74	100	06.15-08.18	■	
1.4 Turbo (68) (B 14 XFL)		Gasolina	FWD	1399	92	125	06.15-08.19	■	
1.4 Turbo (68) (B 14 XFT)		Gasolina	FWD	1399	103	140	07.17-	■	
1.4 Turbo (68) (B 14 XFT)		Gasolina	FWD	1399	110	150	10.15-08.19	■	
1.6 Turbo (68) (B 16 SHT)		Gasolina	FWD	1598	147	200	11.15-02.19	■	
1.4 CNG (68) (B 14 XNT)		Gasol./Gas (CNG)	FWD	1399	81	110	10.17-05.18	■	
1.5 CRDI (68) (D 15 DVC)		Diesel	FWD	1496	77	105	08.19-09.21	■	
1.5 CRDI (68) (F 15 DVC)		Diesel	FWD	1496	77	105	08.19-09.21	■	
1.5 CRDI (68) (D 15 DVH)		Diesel	FWD	1496	90	122	08.19-09.21	■	
1.5 CRDI (68) (F 15 DVH)		Diesel	FWD	1496	90	122	08.19-09.21	■	
1.6 CDTi (68) (B 16 DTE)		Diesel	FWD	1598	70	95	10.15-05.18	■	
1.6 CDTi (68) (B 16 DTE)		Diesel	FWD	1598	81	110	06.15-08.19	■	
1.6 CDTi (68) (B 16 DTU)		Diesel	FWD	1598	81	110	06.15-08.19	■	
1.6 CDTi (68) (D 16 DTI)		Diesel	FWD	1598	81	110	06.15-08.19	■	
1.6 CDTi (68) (B 16 DTH)		Diesel	FWD	1598	100	136	06.15-08.19	■	
1.6 CDTi (68) (D 16 DTH)		Diesel	FWD	1598	100	136	06.15-08.19	■	
1.6 BiTurbo (D 16 DTR)		Diesel	FWD	1598	110	150	07.18-02.19	■	
1.6 CDTi (68) (B 16 DTR)		Diesel	FWD	1598	118	160	11.15-05.18	■	
<b>ASTRA K Sports Tourer (B16) 11.15-</b>						<b>Estate (Compact car-C Segment)</b>			
1.0 Turbo (35) (D 10 XFL)		Gasolina	FWD	999	66	90	06.18-08.19	■	
1.0 Turbo (35) (B 10 XFL)		Gasolina	FWD	999	77	105	06.18-08.19	■	
1.0 Turbo (35) (D 10 XFL)		Gasolina	FWD	999	77	105	06.18-08.19	■	
1.2 Turbo (35) (F 12 SHL)		Gasolina	FWD	1199	81	110	08.19-12.21	■	
1.2 Turbo (35) (F 12 SHT)		Gasolina	FWD	1199	96	131	08.19-12.21	■	
1.2 Turbo (35) (F 12 SHR)		Gasolina	FWD	1199	107	145	08.19-12.21	■	
1.4 Turbo (35) (F 14 SHL)		Gasolina	FWD	1342	107	145	08.19-12.21	■	
1.4 Turbo (35) (F 14 SHT)		Gasolina	FWD	1342	107	145	08.19-12.21	■	
1.4 (35) (B 14 XE)		Gasolina	FWD	1399	74	100	04.16-05.18	■	

# LISTA DE APLICACIONES - BUYERS GUIDE

1.4 Turbo (35) (B 14 XFL)		Gasolina	FWD	1399	92	125	04.16-08.19	■	
1.4 Turbo (35) (B 14 XFT)		Gasolina	FWD	1399	110	150	04.16-08.19	■	
1.4 Turbo (35) (D 14 XFT)		Gasolina	FWD	1399	110	150	04.16-08.19	■	
1.6 Turbo (35) (B 16 SHT)		Gasolina	FWD	1598	147	200	04.16-02.19	■	
1.4 CNG (35) (B 14 XNT)		Gasol./Gas (CNG)	FWD	1399	81	110	08.17-05.18	■	
1.5 CRDI (35) (D 15 DVC)		Diesel	FWD	1496	77	105	08.19-12.21	■	
1.5 CRDI (35) (F 15 DVC)		Diesel	FWD	1496	77	105	08.19-12.21	■	
1.5 CRDI (35) (D 15 DVH)		Diesel	FWD	1496	90	122	08.19-12.21	■	
1.5 CRDI (35) (F 15 DVH)		Diesel	FWD	1496	90	122	08.19-12.21	■	
1.6 CDTi (35) (B 16 DTE)		Diesel	FWD	1598	70	95	04.16-05.18	■	
1.6 CDTi (35) (B 16 DTE)		Diesel	FWD	1598	81	110	04.16-08.19	■	
1.6 CDTi (35) (B 16 DTU)		Diesel	FWD	1598	81	110	04.16-08.19	■	
1.6 CDTi (35) (D 16 DTI)		Diesel	FWD	1598	81	110	04.16-08.19	■	
1.6 CDTi (35) (B 16 DTH)		Diesel	FWD	1598	100	136	04.16-08.19	■	
1.6 BiTurbo (D 16 DTR)		Diesel	FWD	1598	110	150	07.18-02.19	■	
1.6 CDTi (35) (B 16 DTR)		Diesel	FWD	1598	118	160	04.16-05.18	■	
<b>VAUXHALL</b>									
<b>ASTRA Mk VII (K) (B16) 07.15-</b>						<b>Estate (Compact car-C Segment)</b>			
1.0 (B 10 XFL)		Gasolina	FWD	999	77	105	04.16-08.19	■	
1.0 (D 10 XFL)		Gasolina	FWD	999	77	105	04.16-08.19	■	
1.2 Turbo (F 12 SHL)		Gasolina	FWD	1199	81	110	08.19-12.21	■	
1.2 Turbo (F 12 SHT)		Gasolina	FWD	1199	96	131	08.19-12.21	■	
1.2 Turbo (F 12 SHR)		Gasolina	FWD	1199	107	145	08.19-12.21	■	
1.4 Turbo (F 14 SHL)		Gasolina	FWD	1342	107	145	08.19-12.21	■	
1.4 Turbo (F 14 SHT)		Gasolina	FWD	1342	107	145	08.19-12.21	■	
1.4 (B 14 XE)		Gasolina	FWD	1399	74	100	04.16-05.18	■	
1.4 Turbo (B 14 XFL)		Gasolina	FWD	1399	92	125	04.16-05.18	■	
1.4 Turbo (B 14 XFT)		Gasolina	FWD	1399	110	150	04.16-08.19	■	
1.6 Turbo (B 16 SHT)		Gasolina	FWD	1598	147	200	04.16-02.19	■	
1.5 CRDi (D 15 DVC)		Diesel	FWD	1496	77	105	08.19-12.21	■	
1.5 CRDi (F 15 DVC)		Diesel	FWD	1496	77	105	08.19-12.21	■	
1.5 CRDi (D 15 DVH)		Diesel	FWD	1496	90	122	08.19-12.21	■	
1.5 CRDi (F 15 DVH)		Diesel	FWD	1496	90	122	08.19-12.21	■	
1.6 CDTi (B 16 DTE)		Diesel	FWD	1598	70	95	04.16-05.18	■	
1.6 CDTi (B 16 DTE)		Diesel	FWD	1598	81	110	07.15-12.21	■	
1.6 CDTi (B 16 DTU)		Diesel	FWD	1598	81	110	07.15-12.21	■	
1.6 CDTi (D 16 DTI)		Diesel	FWD	1598	81	110	07.15-12.21	■	
1.6 CDTi (B 16 DTH)		Diesel	FWD	1598	100	136	04.16-08.19	■	
1.6 CDTi (D 16 DTH)		Diesel	FWD	1598	100	136	04.16-08.19	■	
1.6 BiTurbo (D 16 DTR)		Diesel	FWD	1598	110	150	07.18-02.19	■	
1.6 CDTi (B 16 DTR)		Diesel	FWD	1598	118	160	04.16-05.18	■	
<b>ASTRA Mk VII (K) (B16) 06.15-12.21</b>						<b>Hatchback (Compact car-C Segment)</b>			
1.0 (B 10 XFL)		Gasolina	FWD	999	77	105	04.16-08.19	■	
1.0 (D 10 XFL)		Gasolina	FWD	999	77	105	04.16-08.19	■	
1.2 Turbo (F 12 SHL)		Gasolina	FWD	1199	81	110	08.19-12.21	■	
1.2 Turbo (F 12 SHT)		Gasolina	FWD	1199	96	131	08.19-12.21	■	
1.2 Turbo (F 12 SHR)		Gasolina	FWD	1199	107	145	08.19-12.21	■	
1.4 Turbo (F 14 SHL)		Gasolina	FWD	1342	107	145	08.19-12.21	■	
1.4 Turbo (F 14 SHT)		Gasolina	FWD	1342	107	145	08.19-12.21	■	

## LISTA DE APLICACIONES - BUYERS GUIDE

1.4 (B 14 XE)		Gasolina	FWD	1399	74	100	04.16-05.18	■
1.4 Turbo (B 14 XFL)		Gasolina	FWD	1399	92	125	04.16-05.18	■
1.4 Turbo (B 14 XFT)		Gasolina	FWD	1399	110	150	04.16-08.19	■
1.6 Turbo (B 16 SHT)		Gasolina	FWD	1598	147	200	04.16-02.19	■
1.5 CRDi (D 15 DVC)		Diesel	FWD	1496	77	105	08.19-12.21	■
1.5 CRDi (F 15 DVC)		Diesel	FWD	1496	77	105	08.19-12.21	■
1.5 CRDi (D 15 DVH)		Diesel	FWD	1496	90	122	08.19-09.21	■
1.5 CRDi (F 15 DVH)		Diesel	FWD	1496	90	122	08.19-09.21	■
1.6 CDTi (B 16 DTE)		Diesel	FWD	1598	70	95	10.15-05.18	■
1.6 CDTi (B 16 DTE)		Diesel	FWD	1598	81	110	06.15-08.19	■
1.6 CDTi (B 16 DTU)		Diesel	FWD	1598	81	110	06.15-08.19	■
1.6 CDTi (D 16 DTI)		Diesel	FWD	1598	81	110	06.15-08.19	■
1.6 CDTi (B 16 DTH)		Diesel	FWD	1598	100	136	06.15-08.19	■
1.6 CDTi (D 16 DTH)		Diesel	FWD	1598	100	136	06.15-08.19	■
1.6 BiTurbo (D 16 DTR)		Diesel	FWD	1598	110	150	07.18-02.19	■
1.6 CDTi (B 16 DTR)		Diesel	FWD	1598	118	160	11.15-05.18	■