

LISTA DE APLICACIONES - BUYERS GUIDE

78BD1558-2



Weight: 5.270

O.E.M.	MAKE
13 502 137	OPEL
1350 2138	OPEL
1350 2139	CHEVROLET
1350 4280	OPEL
1350 5762	BUICK
13504280	VAUXHALL
23 118 061	OPEL
2311 8061	CHEVROLET
23118061	VAUXHALL
23118282	CHEVROLET
5 69 071	OPEL
5 69 075	OPEL
5 69 085	OPEL
5 69 099	OPEL
569071	VAUXHALL
95 527 033	OPEL

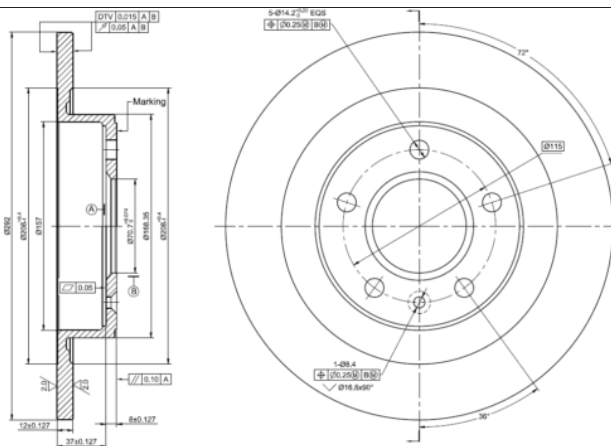

78BD1558-2

E1 90R-02C0415/0092



Ø292x12x45

MAKE
BUICK
BUICK (SGM)
CHEVROLET
CHEVROLET (SGM)
DAEWOO
HOLDEN
OPEL
VAUXHALL



Trac.	CC	Kw	CV
-------	----	----	----



Front / Rear

BUICK

						Convertible (Large family car-D Segment)			
CASCADA 09.15-									
1.6 (LWC)		Gasolina	FWD	1598	149	203	09.15-	■	
VERANO (U.S.A.) 09.11-						Saloon (Compact car-C Segment)			
2.0		Gasolina	FWD	1998	186	253	09.13-	■	
2.4		Gasolina	FWD	2384	134	182	09.13-	■	
2.0 Flex (LHU)		Gasol./Etanol	FWD	1998	186	253	09.12-	■	
2.4 FLEX (LEA)		Gasol./Etanol	FWD	2384	134	182	09.12-	■	

BUICK (SGM)

						Saloon (Compact car-C Segment)			
EXCELLE GT (CP2) 06.10-									
1.4 18T (LFF)		Gasolina	FWD	1372	106	144	03.15-10.17	■	
1.5 15N (L2B)		Gasolina	FWD	1485	84	114	03.15-10.17	■	
1.6		Gasolina	FWD	1598	89	121	06.10-	■	
1.6 T		Gasolina	FWD	1598	135	184	06.10-	■	
1.8 T		Gasolina	FWD	1796	108	147	06.10-	■	
EXCELLE XT (CP2) 01.10-12.15						Hatchback (Compact car-C Segment)			
1.6		Gasolina	FWD	1598	89	121	01.10-	■	
1.6 T		Gasolina	FWD	1598	135	184	01.10-	■	
1.8		Gasolina	FWD	1796	108	147	01.10-	■	

CHEVROLET

						Hatchback (Supermini car-B Segment)			
CRUZE I (J305) 12.10-									
1.4 (A 14 NET)		Gasolina	FWD	1364	103	140	06.12-	■	

LISTA DE APLICACIONES - BUYERS GUIDE

1.4 (LUJ)		Gasolina	FWD	1364	103	140	06.12-	■	
1.4 (LDD)		Gasolina	FWD	1398	74	101	07.13-12.15	■	
1.6 (LXT)		Gasolina	FWD	1598	80	109	01.12-	■	
1.6 (LDE)		Gasolina	FWD	1598	86	117	12.12-	■	
1.6 (LDE)		Gasolina	FWD	1598	91	124	06.11-	■	
1.8 (2H0)		Gasolina	FWD	1796	103	140	10.11-	■	
1.8 (2H0)		Gasolina	FWD	1796	104	141	06.11-	■	
1.8 Flex		Gasolina	FWD	1796	106	144	10.12-	■	
1.8 LPG (2H0)		Gasol./Gas (LPG)	FWD	1796	104	141	06.11-12.15	■	
1.7 TD (LKR)		Diesel	FWD	1686	81	110	08.13-12.15	■	
1.7 D (LUD)		Diesel	FWD	1686	96	131	01.12-12.15	■	
2.0 VCDi		Diesel	RWD	1998	110	150	12.10-	■	
2.0 CDI (LNP)		Diesel	FWD	1998	120	163	06.11-	■	
CRUZE I (J300) 05.09-					Saloon (Supermini car-B Segment)				
1.4 (LUJ)		Gasolina	FWD	1364	103	140	09.10-	■	
1.4 (LDD)		Gasolina	FWD	1398	74	101	07.13-	■	
1.6 (LXT)		Gasolina	FWD	1598	80	109	05.09-	■	
1.6 (LDE)		Gasolina	FWD	1598	83	113	05.09-	■	
1.6 (LDE)		Gasolina	FWD	1598	86	117	12.12-	■	
1.6 (LDE)		Gasolina	FWD	1598	91	124	05.09-	■	
1.8 (LUW,LWE)		Gasolina	FWD	1796	101	137	05.09-	■	
1.8 (LUW)	Eq.V_ J60, disc brak.rear axle	Gasolina	FWD	1796	103	140	11.09-	■	
1.8 (LWE)	Eq.V_ J60, disc brak.rear axle	Gasolina	FWD	1796	103	140	11.09-	■	
1.8 (2H0)		Gasolina	FWD	1796	104	141	05.09-	■	
1.8 Flex		Gasolina	FWD	1796	106	144	01.11-	■	
1.8 LPG (2H0)		Gasol./Gas (LPG)	FWD	1796	104	141	06.11-	■	
1.8 Flex (LUW)		Gasol./Etanol	FWD	1796	101	137	09.13-	■	
1.8 Flex (LUW)		Gasol./Etanol	FWD	1796	103	140	08.15-	■	
1.7 TD (LKR)		Diesel	FWD	1686	81	110	11.13-	■	
1.7 D (LUD)		Diesel	FWD	1686	96	131	01.12-	■	
2.0 CDI (LUZ)		Diesel	FWD	1956	110	150	09.13-	■	
2.0 CDI		Diesel	RWD	1956	113	154	09.13-12.15	■	
2.0 CDI (LLW)		Diesel	FWD	1991	92	125	05.09-05.11	■	
2.0 CDI (LLW)		Diesel	FWD	1991	110	150	05.09-	■	
2.0 CDI (LNP)		Diesel	FWD	1998	120	163	08.10-	■	
2.0 VCDi (LNP)		Diesel	FWD	1998	122	166	03.12-11.18	■	
CRUZE I Station Wagon (J308) 08.12-					Estate (Supermini car-B Segment)				
1.4 (LUJ)		Gasolina	FWD	1364	103	140	08.12-	■	
1.4 (LDD)		Gasolina	FWD	1398	74	101	07.13-12.15	■	
1.6 (LDE)		Gasolina	FWD	1598	86	117	12.12-12.15	■	
1.6 (LDE)		Gasolina	FWD	1598	91	124	08.12-12.15	■	
1.8 (2H0)		Gasolina	FWD	1796	104	141	08.12-	■	
1.7 TD (LKR)		Diesel	FWD	1686	81	110	11.13-12.15	■	
1.7 TD (LUD)		Diesel	FWD	1686	96	131	08.12-	■	
2.0 TD (LNP)		Diesel	FWD	1998	120	163	08.12-	■	
CRUZE II (J405) 01.17-					Hatchback (Supermini car-B Segment)				
1.4 Flex (LE2(85CUL4))		Gasol./Etanol	FWD	1399	113	153	01.17-12.23	■	

LISTA DE APLICACIONES - BUYERS GUIDE

ORLANDO (J309) 12.10-					MPV (Compact MPV-M1 Segment)			
1.4 (LUJ)		Gasolina	FWD	1362	103	140	06.12-	■
1.8 (2H0)		Gasolina	FWD	1796	104	141	02.11-	■
2.4		Gasolina	FWD	2384	130	177	09.11-12.12	■
2.4		Gasolina	FWD	2384	134	182	01.13-	■
1.8 LPG (2H0)		Gasol./Gas (LPG)	FWD	1796	104	141	06.11-12.15	■
2.0 LPG (LTD)		Gasol./Gas (LPG)	FWD	1998	103	140	02.12-	■
2.4 FLEX (LEA)		Gasol./Etanol	FWD	2384	130	177	07.13-	■
1.5 D		Diesel	FWD	1598	98	135	01.13-	■
1.6 D (B 16 DTH)		Diesel	FWD	1598	99	135	01.23-	■
2.0 D (LNP)		Diesel	FWD	1998	96	131	02.11-12.15	■
2.0 D (LNP)		Diesel	FWD	1998	120	163	02.11-	■
VOLT 04.11-					Hatchback (Compact car-C Segment)			
EV 150 (LUU)		Gasol./eléc.	FWD	1398	111	151	11.11-	■
CHEVROLET (SGM)								
CRUZE (CP1) 09.13-					Hatchback (Supermini car-B Segment)			
1.6 (LDE)		Gasolina	FWD	1598	89	121	09.13-02.17	■
1.6 (LLU)		Gasolina	FWD	1598	135	184	09.13-02.17	■
CRUZE (CP1) 04.09-07.16					Saloon (Supermini car-B Segment)			
1.6		Gasolina	FWD	1598	86	117	04.09-	■
1.6 (LDE)		Gasolina	FWD	1598	86	117	04.09-12.13	■
1.6 T		Gasolina	FWD	1598	135	184	11.10-	■
1.8		Gasolina	FWD	1796	105	143	04.09-	■
1.8 (2H0)		Gasolina	FWD	1796	105	143	04.09-12.11	■
DAEWOO								
LACETTI PREMIERE (J300) 02.09-02.11					Saloon (Supermini car-B Segment)			
1.6 (LXV)		Gasolina	FWD	1598	84	114	02.09-02.11	■
2.0 (LLW)		Diesel	FWD	1991	110	150	02.09-02.11	■
HOLDEN								
ASTRA (PJ) 12.14-					Hatchback (Compact car-C Segment)			
1.6 GTC Sport		Gasolina	FWD	1598	125	170	12.14-	■
1.6 GTC Sport		Gasolina	FWD	1598	147	200	12.14-	■
2.0 VXR		Gasolina	FWD	1998	206	280	12.14-	■
ASTRA (BL) 06.17-					Saloon (Compact car-C Segment)			
1.4 (B 14 XFT)		Gasolina	FWD	1399	110	150	06.17-	■
CASCADA (CJ) 08.14-					Convertible (Large family car-D Segment)			
1.6		Gasolina	FWD	1598	125	170	12.14-	■
1.6 (A 16 XHT)		Gasolina	FWD	1598	147	200	08.14-01.15	■
CRUZE II (JH) 06.12-					Estate (Supermini car-B Segment)			
1.8 i		Gasolina	FWD	1796	104	141	06.12-	■
2.0 DTFi		Diesel	RWD	1991	120	163	06.12-	■
CRUZE II (JH) 11.11-					Hatchback (Supermini car-B Segment)			
1.4 i Turbo		Gasolina	FWD	1364	103	140	11.11-	■
1.8 i		Gasolina	FWD	1796	104	141	11.11-	■

LISTA DE APLICACIONES - BUYERS GUIDE

2.0 DTFi		Diesel	RWD	1991	120	163	11.11-	■	
CRUZE II (JG) 06.09-03.11					Saloon (Supermini car-B Segment)				
1.4 i Turbo		Gasolina	FWD	1364	103	140	03.11-	■	
1.8 i		Gasolina	FWD	1796	104	141	06.09-03.11	■	
1.8 i (F18D)		Gasolina	FWD	1796	104	141	04.11-12.16	■	
2.0 DTFi		Diesel	RWD	1991	110	150	06.09-03.11	■	
2.0		Diesel	FWD	1991	120	163	03.11-07.12	■	
2.0 DTFi		Diesel	RWD	1991	120	163	03.11-	■	
VOLT (EV) 04.11-					Saloon (Compact car-C Segment)				
EV 150		Gasolina	FWD		111	151	11.11-	■	
OPEL									
AMPERA (R12) 11.11-					Hatchback (Compact car-C Segment)				
EV 150 (A 14 XFL)		Gasol./el éc.	FWD	1398	111	151	11.11-03.15	■	
ASTRA H CLASSIC (A04) 01.09-05.14					Estate (Compact car-C Segment)				
1.7 CDTi (L35) (A 17 DTR)		Diesel	FWD	1686	92	125	01.09-05.14	■	
1.7 CDTi (L35) (Z 17 DTR)		Diesel	FWD	1686	92	125	01.09-05.14	■	
ASTRA H CLASSIC (A04) 01.09-					Hatchback (Compact car-C Segment)				
1.8 (L48) (Z 18 XER)		Gasolina	FWD	1796	103	140	02.13-05.14	■	
1.7 CDTi (L48) (A 17 DTR)		Diesel	FWD	1686	92	125	01.09-05.14	■	
1.7 CDTi (L48) (Z 17 DTR)		Diesel	FWD	1686	92	125	01.09-05.14	■	
ASTRA J (P10) 09.09-10.15					Estate Van (Compact car-C Segment)				
1.3 CDTi (35) (A 13 DTE)		Diesel	FWD	1248	70	95	10.12-10.15	■	
1.6 CDTi (35) (B 16 DTL)		Diesel	FWD	1598	81	110	01.14-10.15	■	
1.7 CDTi (35) (A 17 DTF)		Diesel	FWD	1686	96	131	10.12-10.15	■	
1.7 CDTi (35) (A 17 DTS)		Diesel	FWD	1686	96	131	10.12-10.15	■	
2.0 CDTi (35) (A 20 DTH)		Diesel	FWD	1956	121	165	10.12-10.15	■	
ASTRA J (P10) 09.09-10.15					Hatchback Van (Compact car-C Segment)				
1.3 CDTi (68) (A 13 DTE)		Diesel	FWD	1248	70	95	05.13-10.15	■	
1.6 CDTi (68) (B 16 DTL)		Diesel	FWD	1598	81	110	01.14-10.15	■	
1.6 CDTi		Diesel	FWD	1598	100	136	05.13-10.15	■	
1.7 CDTi (68) (A 17 DTC)		Diesel	FWD	1686	81	110	05.13-10.15	■	
1.7 CDTi (68) (A 17 DTE)		Diesel	FWD	1686	81	110	05.13-10.15	■	
ASTRA J (P10) 09.09-04.16					Hatchback (Compact car-C Segment)				
1.4 Turbo (68) (A 14 NEL)		Gasolina	FWD	1364	88	120	10.10-10.15	■	
1.4 Turbo (68) (B 14 NEL)		Gasolina	FWD	1364	88	120	10.10-10.15	■	
1.4 Turbo (68) (A 14 NET)		Gasolina	FWD	1364	103	140	12.09-10.15	■	
1.4 Turbo (68) (B 14 NET)		Gasolina	FWD	1364	103	140	12.09-10.15	■	
1.4 (68) (A 14 XEL)		Gasolina	FWD	1398	64	87	12.09-10.15	■	
1.4 (68) (A 14 XER)		Gasolina	FWD	1398	74	100	12.09-10.15	■	
1.4 (68) (B 14 XER)		Gasolina	FWD	1398	74	100	12.09-10.15	■	
1.6 (68) (A 16 XER)		Gasolina	FWD	1598	85	115	12.09-10.15	■	
1.6 (68) (B 16 XER)		Gasolina	FWD	1598	85	115	12.09-10.15	■	
1.6 SIDI (68) (A 16 XHT)		Gasolina	FWD	1598	125	170	12.12-10.15	■	
1.6 SIDI (68) (B 16 SHL)		Gasolina	FWD	1598	125	170	12.12-10.15	■	
1.6 Turbo (68) (A 16 LET)		Gasolina	FWD	1598	132	180	12.09-10.15	■	
1.6 Turbo 4x4 (68) (A 16 LET)		Gasolina	4WD	1598	132	180	12.09-10.15	■	

LISTA DE APLICACIONES - BUYERS GUIDE

1.4 LPG (68) (A 14 NET)		Gasol./Gas (LPG)	FWD	1364	103	140	01.12-10.15	■
1.3 CDTi (68) (A 13 DTE)		Diesel	FWD	1248	70	95	12.09-10.15	■
1.6 CDTi (68) (B 16 DTL)		Diesel	FWD	1598	81	110	02.14-10.15	■
1.6 CDTi (68) (B 16 DTH)		Diesel	FWD	1598	100	136	11.13-10.15	■
1.7 CDTi (68) (A 17 DTC)		Diesel	FWD	1686	81	110	09.09-10.15	■
1.7 CDTi (68) (A 17 DTE)		Diesel	FWD	1686	81	110	09.09-10.15	■
1.7 CDTi (68) (A 17 DTJ)		Diesel	FWD	1686	81	110	09.09-10.15	■
1.7 CDTi (68) (A 17 DTR)		Diesel	FWD	1686	92	125	12.09-10.15	■
1.7 CDTi (68) (A 17 DTF)		Diesel	FWD	1686	96	131	07.11-10.15	■
1.7 CDTi (68) (A 17 DTS)		Diesel	FWD	1686	96	131	07.11-10.15	■
2.0 CDTi (A 20 DTH)		Diesel	FWD	1956	96	131	10.14-10.15	■
2.0 CDTi (68) (A 20 DTH)		Diesel	FWD	1956	118	160	09.09-10.15	■
2.0 CDTi (68) (A 20 DTH)		Diesel	FWD	1956	121	165	06.11-10.15	■
2.0 Biturbo CDTi (68) (A 20 DTR)		Diesel	FWD	1956	143	194	09.12-10.15	■
ASTRA J 06.12-				Saloon (Compact car-C Segment)				
1.4 Turbo (69) (A 14 NEL)		Gasolina	FWD	1364	88	120	06.12-10.15	■
1.4 Turbo (69) (B 14 NEL)		Gasolina	FWD	1364	88	120	06.12-10.15	■
1.4 Turbo (69) (A 14 NET)		Gasolina	FWD	1364	103	140	06.12-06.18	■
1.4 Turbo (69) (B 14 NET)		Gasolina	FWD	1364	103	140	06.12-06.18	■
1.4 (A 14 XEL)		Gasolina	FWD	1398	64	87	01.14-10.15	■
1.4 (69) (A 14 XER)		Gasolina	FWD	1398	74	101	06.12-10.15	■
1.4 (69) (B 14 XER)		Gasolina	FWD	1398	74	101	06.12-10.15	■
1.6 (69) (A 16 XER)		Gasolina	FWD	1598	85	116	06.12-06.18	■
1.6 (69) (B 16 XER)		Gasolina	FWD	1598	85	116	06.12-06.18	■
1.6 SIDI (69) (A 16 XHT)		Gasolina	FWD	1598	125	170	06.12-10.15	■
1.6 Turbo (69) (A 16 LET)		Gasolina	FWD	1598	132	180	06.12-10.13	■
1.4 Turbo LPG (69) (A 14 NET)		Gasol./Gas (LPG)	FWD	1364	103	140	07.14-06.18	■
1.3 CDTi (69) (A 13 DTE)		Diesel	FWD	1248	70	95	06.12-10.15	■
1.6 CDTi (69) (B 16 DTL)		Diesel	FWD	1598	81	110	04.14-06.18	■
1.6 CDTi (69) (B 16 DTH)		Diesel	FWD	1598	100	136	01.14-06.18	■
1.7 CDTi		Diesel	FWD	1686	74	101	06.12-10.15	■
1.7 CDTi (69) (A 17 DTC)		Diesel	FWD	1686	81	110	06.12-10.15	■
1.7 CDTi (69) (A 17 DTE)		Diesel	FWD	1686	81	110	06.12-10.15	■
1.7 CDTi (69) (A 17 DTJ)		Diesel	FWD	1686	81	110	06.12-10.15	■
1.7 CDTi (69) (A 17 DTF)		Diesel	FWD	1686	96	131	06.12-10.15	■
1.7 CDTi (69) (A 17 DTS)		Diesel	FWD	1686	96	131	06.12-10.15	■
ASTRA J GTC 10.11-				Hatchback (Compact car-C Segment)				
1.4 (08) (A 14 NEL)		Gasolina	FWD	1364	88	120	10.11-04.18	■
1.4 (08) (B 14 NEL)		Gasolina	FWD	1364	88	120	10.11-04.18	■
1.4 Turbo (08) (A 14 NET)		Gasolina	FWD	1364	103	140	10.11-04.18	■
1.4 Turbo (08) (B 14 NET)		Gasolina	FWD	1364	103	140	10.11-04.18	■
1.4 (08) (A 14 XER)		Gasolina	FWD	1398	74	101	10.11-11.13	■
1.6 SIDI (08) (A 16 XHT)		Gasolina	FWD	1598	125	170	12.12-04.18	■
1.6 SIDI (08) (B 16 SHL)		Gasolina	FWD	1598	125	170	12.12-04.18	■
1.6 Turbo (08) (A 16 LET)		Gasolina	FWD	1598	132	180	10.11-06.13	■
1.6 SIDI (08) (A 16 SHT)		Gasolina	FWD	1598	147	200	07.13-04.18	■
1.6 SIDI (08) (B 16 SHT)		Gasolina	FWD	1598	147	200	07.13-04.18	■
1.8 (08) (A 18 XER)		Gasolina	FWD	1796	103	140	10.11-10.13	■
1.6 CDTi (08) (B 16 DTL)		Diesel	FWD	1598	81	110	07.14-04.18	■
1.6 CDTi (08) (B 16 DTH)		Diesel	FWD	1598	100	136	07.14-04.18	■

LISTA DE APLICACIONES - BUYERS GUIDE

1.7 CDTI (08) (A 17 DTC)		Diesel	FWD	1686	81	110	03.12-10.13	■
1.7 CDTI (08) (A 17 DTE)		Diesel	FWD	1686	81	110	03.12-10.13	■
1.7 CDTI (08) (A 17 DTJ)		Diesel	FWD	1686	81	110	03.12-10.13	■
1.7 CDTI (08) (A 17 DTF)		Diesel	FWD	1686	96	131	03.12-06.14	■
1.7 CDTI (08) (A 17 DTS)		Diesel	FWD	1686	96	131	03.12-06.14	■
2.0 CDTI (08) (A 20 DTH)		Diesel	FWD	1956	96	131	01.12-10.15	■
2.0 CDTI (08) (A 20 DTH)		Diesel	FWD	1956	121	165	01.12-06.15	■
2.0 BiTurbo CDTI (08) (A 20 DTR)		Diesel	FWD	1956	143	194	10.13-06.15	■
ASTRA J Sports Tourer (P10) 10.10-				Estate (Compact car-C Segment)				
1.4 Turbo (35) (A 14 NEL)		Gasolina	FWD	1364	88	120	10.10-10.15	■
1.4 Turbo (35) (B 14 NEL)		Gasolina	FWD	1364	88	120	10.10-10.15	■
1.4 Turbo (35) (A 14 NET)		Gasolina	FWD	1364	103	140	10.10-10.15	■
1.4 Turbo (35) (B 14 NET)		Gasolina	FWD	1364	103	140	10.10-10.15	■
1.4 (35) (A 14 XEL)		Gasolina	FWD	1398	64	87	10.10-10.15	■
1.4 (35) (A 14 XER)		Gasolina	FWD	1398	74	101	10.10-10.15	■
1.4 (35) (B 14 XER)		Gasolina	FWD	1398	74	101	10.10-10.15	■
1.6 (35) (A 16 XER)		Gasolina	FWD	1598	85	116	10.10-10.15	■
1.6 (35) (B 16 XER)		Gasolina	FWD	1598	85	116	10.10-10.15	■
1.6 SIDI (35) (A 16 XHT)		Gasolina	FWD	1598	125	170	12.12-10.15	■
1.6 SIDI (35) (B 16 SHL)		Gasolina	FWD	1598	125	170	12.12-10.15	■
1.6 Turbo (35) (A 16 LET)		Gasolina	FWD	1598	132	180	10.10-10.15	■
1.4 LPG (35) (A 14 NET)		Gasol./G as (LPG)	FWD	1364	103	140	12.11-10.15	■
1.3 CDTI (35) (A 13 DTE)		Diesel	FWD	1248	70	95	10.10-10.14	■
1.6 CDTi (35) (B 16 DTL)		Diesel	FWD	1598	81	110	02.14-10.15	■
1.6 CDTi (35) (B 16 DTH)		Diesel	FWD	1598	100	136	11.13-10.15	■
1.7 CDTI (35) (A 17 DTL)		Diesel	FWD	1686	74	101	10.10-10.15	■
1.7 CDTI (35) (A 17 DTN)		Diesel	FWD	1686	74	101	10.10-10.15	■
1.7 CDTI (35) (A 17 DTC)		Diesel	FWD	1686	81	110	10.10-10.15	■
1.7 CDTI (35) (A 17 DTE)		Diesel	FWD	1686	81	110	10.10-10.15	■
1.7 CDTI (35) (A 17 DTJ)		Diesel	FWD	1686	81	110	10.10-10.15	■
1.7 CDTI (35) (A 17 DTR)		Diesel	FWD	1686	92	125	10.10-10.15	■
1.7 CDTI (35) (A 17 DTF)		Diesel	FWD	1686	96	131	10.10-10.15	■
1.7 CDTI (35) (A 17 DTS)		Diesel	FWD	1686	96	131	10.10-10.15	■
2.0 CDTI (35)		Diesel	FWD	1956	96	131	01.14-10.15	■
2.0 CDTI (35) (A 20 DTH)		Diesel	FWD	1956	118	160	10.10-10.15	■
2.0 CDTI (35) (A 20 DTH)		Diesel	FWD	1956	121	165	08.11-10.15	■
2.0 Biturbo CDTI (35) (A 20 DTR)		Diesel	FWD	1956	143	194	09.12-10.15	■
CASCADA (W13) 03.13-				Convertible (Large family car-D Segment)				
1.4 (67) (A 14 NEL)		Gasolina	FWD	1364	88	120	04.13-04.18	■
1.4 (67) (B 14 NEL)		Gasolina	FWD	1364	88	120	04.13-04.18	■
1.4 Turbo (67) (A 14 NET)		Gasolina	FWD	1364	103	140	03.13-04.18	■
1.4 Turbo (67) (B 14 NET)		Gasolina	FWD	1364	103	140	03.13-04.18	■
1.6 (67) (D 16 SHJ)		Gasolina	FWD	1598	100	136	05.18-04.19	■
1.6 SIDI (67) (A 16 XHT)		Gasolina	FWD	1598	125	170	04.13-04.19	■
1.6 SIDI (67) (B 16 SHL)		Gasolina	FWD	1598	125	170	04.13-04.19	■
1.6 SIDI (67) (D 16 SHL)		Gasolina	FWD	1598	125	170	04.13-04.19	■
1.6 (67) (A 16 SHT)		Gasolina	FWD	1598	147	200	11.13-04.18	■
1.6 (67) (B 16 SHT)		Gasolina	FWD	1598	147	200	11.13-04.18	■
2.0 CDTI (67) (A 20 DTH)		Diesel	FWD	1956	121	165	04.13-06.15	■
2.0 CDTI (67) (B 20 DTH)		Diesel	FWD	1956	125	170	07.15-04.18	■

LISTA DE APLICACIONES - BUYERS GUIDE

2.0 CDTi (67) (A 20 DTR)		Diesel	FWD	1956	143	194	04.13-06.15	■	
ZAFIRA Tourer C (P12) 10.11-					MPV (Compact MPV-M1 Segment)				
1.4 (75) (A 14 NEL)		Gasolina	FWD	1364	88	120	10.11-05.18	■	
1.4 (75) (B 14 NEL)		Gasolina	FWD	1364	88	120	10.11-05.18	■	
1.4 (75) (A 14 NET)		Gasolina	FWD	1364	103	140	10.11-05.18	■	
1.4 (75) (B 14 NET)		Gasolina	FWD	1364	103	140	10.11-05.18	■	
1.6 (75) (D 16 SHJ)		Gasolina	FWD	1598	100	136	09.18-07.19	■	
1.6 (75) (A 16 XHT)		Gasolina	FWD	1598	125	170	12.12-03.19	■	
1.6 (75) (B 16 SHL)		Gasolina	FWD	1598	125	170	12.12-03.19	■	
1.6 (75) (D 16 SHL)		Gasolina	FWD	1598	125	170	12.12-03.19	■	
1.6 SIDI (75) (A 16 SHT)		Gasolina	FWD	1598	147	200	07.13-05.18	■	
1.6 SIDI (75) (B 16 SHT)		Gasolina	FWD	1598	147	200	07.13-05.18	■	
1.8 (75) (A 18 XEL)		Gasolina	FWD	1796	85	115	10.11-06.15	■	
1.8 (75) (A 18 XER)		Gasolina	FWD	1796	103	140	10.11-05.18	■	
1.4 LPG (75) (A 14 NET)		Gasol./Gas (LPG)	FWD	1364	103	140	10.11-05.18	■	
1.4 LPG (75) (B 14 NET)		Gasol./Gas (LPG)	FWD	1364	103	140	10.11-05.18	■	
1.6 CNG (75) (A 16 XNT)		Gasol./Gas (CNG)	FWD	1598	110	150	10.11-05.18	■	
1.6 CNG (75) (B 16 XNT)		Gasol./Gas (CNG)	FWD	1598	110	150	10.11-05.18	■	
1.6 CDTi (75) (B 16 DTJ)		Diesel	FWD	1598	88	120	07.14-11.18	■	
1.6 CDTi (75) (D 16 DTJ)		Diesel	FWD	1598	88	120	07.14-11.18	■	
1.6 CDTi (75) (B 16 DTH)		Diesel	FWD	1598	99	134	07.13-03.19	■	
1.6 CDTi (75) (D 16 DTH)		Diesel	FWD	1598	99	134	07.13-03.19	■	
1.6 CDTi (75) (B 16 DTH)		Diesel	FWD	1598	100	136	02.13-05.16	■	
2.0 CDTi (75) (A 20 DTL)		Diesel	FWD	1956	81	110	10.11-10.14	■	
2.0 CDTi (75) (A 20 DT)		Diesel	FWD	1956	96	130	10.11-11.18	■	
2.0 CDTi (75) (B 20 DTJ)		Diesel	FWD	1956	96	130	10.11-11.18	■	
2.0 CDTi (75) (D 20 DTJ)		Diesel	FWD	1956	96	130	10.11-11.18	■	
2.0 CDTi (75) (Y 20 DTJ)		Diesel	FWD	1956	96	130	10.11-11.18	■	
2.0 CDTi (75) (Z 20 DTJ)		Diesel	FWD	1956	96	130	10.11-11.18	■	
2.0 CDTi (75) (A 20 DTH)		Diesel	FWD	1956	121	165	10.11-10.14	■	
2.0 CDTi (75) (B 20 DTH)		Diesel	FWD	1956	125	170	11.14-03.19	■	
2.0 CDTi (75) (D 20 DTH)		Diesel	FWD	1956	125	170	11.14-03.19	■	
2.0 BiTurbo CDTi (75) (A 20 DTR)		Diesel	FWD	1956	143	194	01.13-10.14	■	
ZAFIRA TOURER C VAN (P12) 10.11-					Box Body/MPV (Compact MPV-M1 Segment)				
2.0 CDTi (75)		Diesel	FWD	1956	81	110	01.13-10.14	■	
2.0 CDTi (75)		Diesel	FWD	1956	96	131	01.12-10.14	■	
2.0 CDTi (75)		Diesel	FWD	1956	121	165	01.13-10.14	■	
VAUXHALL									
AMPERA (R12) 03.12-					Hatchback (Compact car-C Segment)				
EV 150 (D1JOI) (4ET50)		Gasol./el éc.	FWD	1398	111	151	03.12-	■	
EV 150 (D1JOI) (A 14 XFL)		Gasol./el éc.	FWD	1398	111	151	03.12-	■	
ASTRA Mk VI (J) (P10) 10.10-					Estate (Compact car-C Segment)				
1.4 Turbo (A 14 NET)		Gasolina	FWD	1364	103	140	10.10-10.15	■	
1.4 (A 14 XEL)		Gasolina	FWD	1398	64	87	10.10-10.15	■	
1.4 (A 14 XER)		Gasolina	FWD	1398	74	101	10.10-10.15	■	

LISTA DE APLICACIONES - BUYERS GUIDE

1.4 (B 14 XER)		Gasolina	FWD	1398	74	101	10.10-10.15	■	
1.6 (A 16 XER)		Gasolina	FWD	1598	85	116	10.10-10.15	■	
1.6 (B 16 XER)		Gasolina	FWD	1598	85	116	10.10-10.15	■	
1.6 SIDI		Gasolina	FWD	1598	125	170	12.12-10.15	■	
1.6 Turbo (A 16 LET)		Gasolina	FWD	1598	132	180	10.10-10.15	■	
1.3 CDTi (A 13 DTE)		Diesel	FWD	1248	70	95	10.10-10.15	■	
1.6 CDTi (B 16 DTL)		Diesel	FWD	1598	81	110	01.14-10.15	■	
1.6 CDTi (B 16 DTH)		Diesel	FWD	1598	100	136	01.14-10.15	■	
1.7 CDTi (A 17 DTC)		Diesel	FWD	1686	81	110	10.10-10.15	■	
1.7 CDTi (A 17 DTE)		Diesel	FWD	1686	81	110	10.10-10.15	■	
1.7 CDTi (A 17 DTJ)		Diesel	FWD	1686	81	110	10.10-10.15	■	
1.7 CDTi (A 17 DTR)		Diesel	FWD	1686	92	125	10.10-10.15	■	
1.7 CDTi (A 17 DTF)		Diesel	FWD	1686	96	131	06.11-10.15	■	
1.7 CDTi (A 17 DTS)		Diesel	FWD	1686	96	131	06.11-10.15	■	
2.0 CDTi (A 20 DTH)		Diesel	FWD	1956	118	160	10.10-06.11	■	
2.0 CDTi (A 20 DTH)		Diesel	FWD	1956	121	165	08.11-10.15	■	
2.0 BiTurbo CDTi (A 20 DTR)		Diesel	FWD	1956	143	194	12.12-10.15	■	
ASTRA Mk VI (J) (P10) 12.09-							Hatchback (Compact car-C Segment)		
1.4 Turbo (A 14 NEL)		Gasolina	FWD	1364	88	120	08.10-10.15	■	
1.4 Turbo (A 14 NET)		Gasolina	FWD	1364	103	140	12.09-10.15	■	
1.4 Turbo (B 14 NET)		Gasolina	FWD	1364	103	140	12.09-10.15	■	
1.4 Turbo (D 14 NET)		Gasolina	FWD	1364	103	140	12.09-10.15	■	
1.4 (A 14 XEL)		Gasolina	FWD	1398	64	87	12.09-10.15	■	
1.4 (A 14 XER)		Gasolina	FWD	1398	74	100	12.09-10.15	■	
1.4 (B 14 XER)		Gasolina	FWD	1398	74	100	12.09-10.15	■	
1.6 (A 16 XER)		Gasolina	FWD	1598	85	115	12.09-10.15	■	
1.6 (B 16 XER)		Gasolina	FWD	1598	85	115	12.09-10.15	■	
1.6 SIDI		Gasolina	FWD	1598	125	170	12.12-10.15	■	
1.6 Turbo (A 16 LET)		Gasolina	FWD	1598	132	180	12.09-10.15	■	
1.3 CDTi (A 13 DTE)		Diesel	FWD	1248	70	95	12.09-10.15	■	
1.6 CDTi (B 16 DTL)		Diesel	FWD	1598	81	110	11.13-10.15	■	
1.6 CDTi (B 16 DTH)		Diesel	FWD	1598	100	136	11.13-10.15	■	
1.7 CDTi (A 17 DTL)		Diesel	FWD	1686	74	101	10.10-10.15	■	
1.7 CDTi (A 17 DTC)		Diesel	FWD	1686	81	110	12.09-10.15	■	
1.7 CDTi (A 17 DTE)		Diesel	FWD	1686	81	110	12.09-10.15	■	
1.7 CDTi (A 17 DTJ)		Diesel	FWD	1686	81	110	12.09-10.15	■	
1.7 CDTi (A 17 DTR)		Diesel	FWD	1686	92	125	12.09-10.15	■	
1.7 CDTi (A 17 DTF)		Diesel	FWD	1686	96	131	06.11-10.15	■	
1.7 CDTi (A 17 DTS)		Diesel	FWD	1686	96	131	06.11-10.15	■	
2.0 CDTi (A 20 DTH)		Diesel	FWD	1956	118	160	12.09-06.11	■	
2.0 CDTi (A 20 DTH)		Diesel	FWD	1956	121	165	08.11-10.15	■	
2.0 BiTurbo CDTi (A 20 DTR)		Diesel	FWD	1956	143	194	12.12-10.15	■	
ASTRA Mk VI (J) (P10) 06.12-							Saloon (Compact car-C Segment)		
1.4 Turbo (A 14 NET)		Gasolina	FWD	1364	103	140	06.12-10.15	■	
1.4 (A 14 XER)		Gasolina	FWD	1398	74	101	06.12-10.15	■	
1.6 (A 16 XER)		Gasolina	FWD	1598	85	116	06.12-10.15	■	
1.6 SIDI		Gasolina	FWD	1598	125	170	06.12-10.15	■	
1.6 Turbo (A 16 LET)		Gasolina	FWD	1598	132	180	06.12-10.15	■	
1.3 CDTi (A 13 DTE)		Diesel	FWD	1248	70	95	06.12-10.15	■	
1.7 CDTi (A 17 DTC)		Diesel	FWD	1686	81	110	06.12-10.15	■	

LISTA DE APLICACIONES - BUYERS GUIDE

1.7 CDTi (A 17 DTE)		Diesel	FWD	1686	81	110	06.12-10.15	■	
1.7 CDTi (A 17 DTJ)		Diesel	FWD	1686	81	110	06.12-10.15	■	
1.7 CDTi (A 17 DTF)		Diesel	FWD	1686	96	131	06.12-10.15	■	
1.7 CDTi (A 17 DTS)		Diesel	FWD	1686	96	131	06.12-10.15	■	
ASTRA Mk VI (J) GTC (P10) 10.11-							Hatchback (Compact car-C Segment)		
1.4 (A 14 NEL)		Gasolina	FWD	1364	88	120	10.11-10.18	■	
1.4 (B 14 NEL)		Gasolina	FWD	1364	88	120	10.11-10.18	■	
1.4 (A 14 NET)		Gasolina	FWD	1364	103	140	10.11-04.18	■	
1.4 (B 14 NET)		Gasolina	FWD	1364	103	140	10.11-04.18	■	
1.4 (A 14 XER)		Gasolina	FWD	1398	74	101	10.11-10.18	■	
1.6 SIDI		Gasolina	FWD	1598	125	170	09.13-10.18	■	
1.6 (A 16 LET)		Gasolina	FWD	1598	132	180	10.11-10.18	■	
1.6 SIDI (A 16 SHT)		Gasolina	FWD	1598	147	200	09.13-10.18	■	
1.6 SIDI (B 16 SHT)		Gasolina	FWD	1598	147	200	09.13-10.18	■	
2.0 VXR (A 20 NFT)		Gasolina	FWD	1998	206	280	04.12-10.18	■	
2.0 VXR (B 20 NFT)		Gasolina	FWD	1998	206	280	04.12-10.18	■	
1.6 CDTi (B 16 DTL)		Diesel	FWD	1598	81	110	07.14-10.18	■	
1.6 CDTi (B 16 DTH)		Diesel	FWD	1598	100	136	07.14-10.18	■	
1.7 CDTi (A 17 DTC)		Diesel	FWD	1686	81	110	10.11-10.18	■	
1.7 CDTi (A 17 DTE)		Diesel	FWD	1686	81	110	10.11-10.18	■	
1.7 CDTi (A 17 DTJ)		Diesel	FWD	1686	81	110	10.11-10.18	■	
1.7 CDTi (A 17 DTF)		Diesel	FWD	1686	96	131	10.11-10.18	■	
1.7 CDTi (A 17 DTS)		Diesel	FWD	1686	96	131	10.11-10.18	■	
2.0 CDTi (A 20 DTH)		Diesel	FWD	1956	121	165	10.11-10.18	■	
2.0 BiTurbo CDTi (A 20 DTR)		Diesel	FWD	1956	143	194	12.12-10.18	■	
CASCADA (W13) 02.13-							Convertible (Large family car-D Segment)		
1.4 (A 14 NET)		Gasolina	FWD	1364	103	140	02.13-	■	
1.4 (B 14 NET)		Gasolina	FWD	1364	103	140	02.13-	■	
1.6		Gasolina	FWD	1598	100	136	05.18-04.19	■	
1.6 (A 16 XHT)		Gasolina	FWD	1598	125	170	02.13-	■	
1.6 (B 16 SHL)		Gasolina	FWD	1598	125	170	02.13-	■	
1.6 (A 16 SHT)		Gasolina	FWD	1598	147	200	11.13-	■	
1.6 (B 16 SHT)		Gasolina	FWD	1598	147	200	11.13-	■	
2.0 CDTi (A 20 DTH)		Diesel	FWD	1956	121	165	02.13-	■	
2.0 CDTi (B 20 DTH)		Diesel	FWD	1956	125	170	07.15-	■	
2.0 CDTi (A 20 DTR)		Diesel	FWD	1956	143	194	02.13-	■	
ZAFIRA Mk III (P12) 10.11-							MPV (Compact MPV-M1 Segment)		
1.4 (75) (A 14 NEL)		Gasolina	FWD	1364	88	120	10.11-06.14	■	
1.4 (75) (A 14 NET)		Gasolina	FWD	1364	103	140	10.11-05.18	■	
1.4 (75) (B 14 NET)		Gasolina	FWD	1364	103	140	10.11-05.18	■	
1.6 SIDI		Gasolina	FWD	1598	125	170	12.12-03.19	■	
1.6 SIDI (75) (A 16 SHT)		Gasolina	FWD	1598	147	200	07.13-05.18	■	
1.8 (75) (A 18 XEL)		Gasolina	FWD	1796	85	116	10.11-06.15	■	
1.8 (75) (A 18 XER)		Gasolina	FWD	1796	103	140	10.11-05.18	■	
1.6 CNG (75) (A 16 XNT)		Gasol./Gas (CNG)	FWD	1598	110	150	10.11-04.16	■	
1.6 CDTi (75) (B 16 DTH)		Diesel	FWD	1598	99	135	07.13-05.16	■	
1.6 CDTi (75) (B 16 DTH)		Diesel	FWD	1598	100	136	02.13-05.16	■	
2.0 CDTi (75) (A 20 DTL)		Diesel	FWD	1956	81	110	09.11-10.14	■	
2.0 CDTi (75) (A 20 DT)		Diesel	FWD	1956	96	130	10.11-10.14	■	

LISTA DE APLICACIONES - BUYERS GUIDE

2.0 CDTi (75) (Y 20 DTJ)	Diesel	FWD	1956	96	130	10.11-10.14
2.0 CDTi (75) (Z 20 DTJ)	Diesel	FWD	1956	96	130	10.11-10.14
2.0 CDTi (75) (A 20 DTH)	Diesel	FWD	1956	121	165	10.11-10.14
2.0 CDTi (75) (B 20 DTH)	Diesel	FWD	1956	125	170	11.14-05.18
2.0 BiTurbo CDTi (75) (A 20 DTR)	Diesel	FWD	1956	143	194	11.12-08.18

