

LISTA DE APLICACIONES - BUYERS GUIDE

78BD2038-2



Weight: 10.150

O.E.M.	MAKE
435120D090	TOYOTA
435120D130	TOYOTA
435120D220	TOYOTA (FAW)
435120D230	TOYOTA
43512-52120	TOYOTA

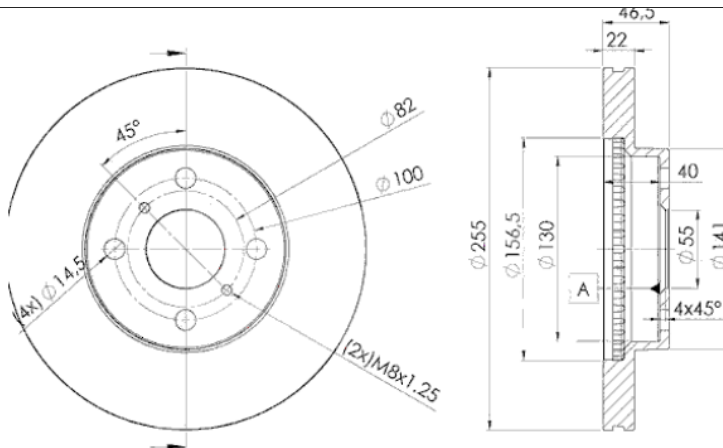

78BD2038-2

E1 90R-02C0074/0061



Ø255x22x46

MAKE
PERODUA
TOYOTA



Trac.	CC	Kw	CV
-------	----	----	----



Front / Rear

PERODUA

ALZA (M502) 03.09-				MPV (Compact MPV-M1 Segment)			
1.5 (D46T, D49A, D53L) (3SZ-VE)	Gasolina	FWD	1495	76	103	03.09-	■

TOYOTA

AQUA (_NHP1_) 12.11-				Hatchback (Supermini car-B Segment)			
1.5 Hybrid (NHP10)	Gasol./el éc.	FWD	1496	54	73	12.11-	■

COROLLA XI / COROLLA AXIO (_E16_) 05.12-				Saloon (Compact executive car-D Segment)			
1.3 (NRE160)	Gasolina	FWD	1329	70	95	05.12-	■
1.5 (NRE161)	Gasolina	FWD	1496	80	109	03.15-	■
1.5 4WD (NZE164)	Gasolina	4WD	1497	76	103	05.12-	■
1.5 (NZE161)	Gasolina	FWD	1497	80	109	05.12-	■
1.5 Hybrid (NKE165)	Gasol./el éc.	FWD	1496	54	73	07.13-	■

COROLLA XI / COROLLA FIELDER (_E16_) 05.12-				Estate (Compact executive car-D Segment)			
1.5 Hybrid (NKE165G)	Gasol./el éc.	FWD	1496	54	73	10.14-	■

PRIUS III C / AQUA (NHP10_) 09.11-				Hatchback (Executive car-E Segment)			
1.5 Hybrid (NHP10)	Gasol./el éc.	FWD	1497	74	101	09.11-	■

YARIS II / VITZ (_P9_) 01.05-				Hatchback (Supermini car-B Segment)			
1.0 VVT-i (KSP90_, KSP90R) (1KR-FE)	Gasolina	FWD	998	51	69	08.05-12.11	■
1.0 VVT-i (KSP90)	Gasolina	FWD	998	52	71	11.05-11.10	■
1.3 VVT-i (SCP90_, SCP90R) (2SZ-FE)	Gasolina	FWD	1298	64	87	08.05-11.10	■

LISTA DE APLICACIONES - BUYERS GUIDE

1.33 VVT-i (NSP90_, NSP90R) (1NR-FE)	Gasolina	FWD	1329	74	100	11.08-12.11	■
1.5 (NCP91_, NCP91R) (1NZ-FE)	Gasolina	FWD	1497	80	109	11.05-12.14	■
1.4 D-4D (NLP90_, NLP90R) (1ND-TV)	Diesel	FWD	1364	66	90	08.05-12.12	■
YARIS III / VITZ (_P13_) 12.10-				Hatchback (Supermini car-B Segment)			
1.3 (NCP130_, NCP130R) (2NZ-FE)	Gasolina	FWD	1299	63	86	12.11-01.17	■
1.3 4WD (NSP135_, NSP135) (1NR-FE)	Gasolina	4WD	1329	70	95	12.10-01.20	■
1.5 (NCP131_, NCP131R) (1NZ-FE)	Gasolina	FWD	1497	80	109	12.10-01.20	■