

LISTA DE APLICACIONES - BUYERS GUIDE

78BD6035-2

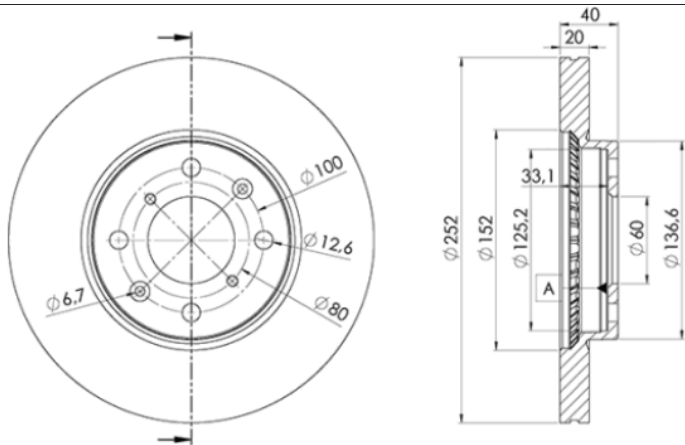

Weight: 9.356



78BD6035-2

E1 90R-02C0452/0074



Ø252x20x40

O.E.M.	MAKE
47 00 455	OPEL
47 08 241	OPEL
47 10 944	OPEL
55311-62J00	SUZUKI
55311-62J01	SUZUKI
93 192 978	VAUXHALL
93 194 988	VAUXHALL
93 513 700	VAUXHALL
95 513 700	OPEL

MAKE
GERMAN E CARS
OPEL
SUZUKI
VAUXHALL



Trac.	CC	Kw	CV
-------	----	----	----



Front / Rear

GERMAN E CARS

STROMOS 09.10-

Hatchback ()

Elektro		Eléctrico	FWD		56	76	09.10-	■
---------	--	-----------	-----	--	----	----	--------	---

OPEL

AGILA B (H08) 04.08-

Hatchback (City car-A Segment)

1.0 (F68) (K10B)	05/08-	Gasolina	FWD	996	48	65	04.08-06.11	■
1.0 (F68) (K10B)		Gasolina	FWD	996	50	68	07.11-07.14	■
1.2 (F68) (K12B)	05/08-	Gasolina	FWD	1242	63	86	04.08-10.12	■
1.2 (F68) (K12B)		Gasolina	FWD	1242	69	94	04.10-10.14	■
1.0 LPG (F68) (K10B)		Gasol./Gas (LPG)	FWD	996	48	65	01.10-06.11	■
1.2 LPG (F68) (K12B)		Gasol./Gas (LPG)	FWD	1242	63	86	04.08-10.10	■
1.3 CDTI (F68) (D13A)	05/08-	Diesel	FWD	1248	55	75	04.08-04.10	■
1.3 CDTI (F68) (Z 13 DTJ)	05/08-	Diesel	FWD	1248	55	75	04.08-04.10	■

SUZUKI

SPLASH (EX) 01.08-

Hatchback (City car-A Segment)

1.0 (A5B310) (K10B)		Gasolina	FWD	996	48	65	01.08-	■
1.0 (A5B310) (K10B)		Gasolina	FWD	996	50	68	06.11-	■
1.2		Gasolina	FWD	1197	63	85	05.09-	■
1.2 (A5B412) (K12B)		Gasolina	FWD	1242	63	86	01.08-	■
1.2 VVT (A5B412) (K12B)		Gasolina	FWD	1242	66	90	06.11-	■
1.2 VVT (A5B412, XB32S) (K12B)		Gasolina	FWD	1242	67	91	08.12-	■
1.2 VVT (A5B412) (K12B)		Gasolina	FWD	1242	69	94	09.10-	■
1.2 LPG (K12B)		Gasol./Gas (LPG)	FWD	1242	63	86	04.08-12.14	■

LISTA DE APLICACIONES - BUYERS GUIDE

1.3 CDTI (A5B413D) (D13A)		Diesel	FWD	1248	55	75	01.08-	■	
1.3 CDTI (A5B413D) (Z 13 DTJ)		Diesel	FWD	1248	55	75	01.08-	■	
SWIFT III (MZ, EZ) 02.05-							Hatchback (Supermini car-B Segment)		
1.2 (ZC71S) (K12B)		Gasolina	FWD	1242	66	90	04.08-12.10	■	
1.3 4x4 (RS413, ZD11S) (M13A)		Gasolina	4WD	1328	66	90	01.06-06.12	■	
1.3 (RS413, ZC11S) (M13A)		Gasolina	FWD	1328	67	91	02.05-06.15	■	
1.3 (RS413, ZC11S) (M13A)		Gasolina	FWD	1328	68	92	02.05-06.12	■	
1.3 4x4 (RS413, ZD11S) (M13A)		Gasolina	4WD	1328	68	92	02.05-06.12	■	
1.5 4x4 (RS 415, ZD21S) (M15A)		Gasolina	4WD	1490	74	101	02.05-01.11	■	
1.5 (RS415, ZC21S) (M15A)		Gasolina	FWD	1490	75	102	02.05-12.11	■	
1.6 (RS416, RR 416, ZC31S) (M16A)		Gasolina	FWD	1586	92	125	05.06-12.15	■	
1.3 LPG (RS 413) (M13A)		Gasol./Gas (LPG)	FWD	1328	68	92	09.08-12.10	■	
1.3 DDiS (RS413D) (Z13DT)		Diesel	FWD	1248	51	69	08.05-06.12	■	
1.3 DDiS (RS413D) (D13A)		Diesel	FWD	1248	55	75	08.05-12.11	■	
1.3 DDiS (RS413D) (Z 13 DTJ)		Diesel	FWD	1248	55	75	08.05-12.11	■	
VAUXHALL									
AGILA Mk II (B) (H08) 01.08-11.14							Hatchback (City car-A Segment)		
1.0 12V (K10B)		Gasolina	FWD	996	48	65	01.08-11.14	■	
1.0 i (K10B)		Gasolina	FWD	996	50	68	08.11-11.14	■	
1.2 i 16V (K12B)		Gasolina	FWD	1242	63	86	01.08-11.14	■	
1.2 i 16V (K12B)		Gasolina	FWD	1242	69	94	01.08-11.14	■	
1.3 CDTi (D13A)		Diesel	FWD	1248	55	75	01.08-11.14	■	
1.3 CDTi (Z 13 DTJ)		Diesel	FWD	1248	55	75	01.08-11.14	■	