

# LISTA DE APLICACIONES - BUYERS GUIDE

## 78BD9007-2



Weight: 12.864

| O.E.M.     | MAKE     |
|------------|----------|
| 5 69 007   | OPEL     |
| 56 90 07   | VAUXHALL |
| 93 181 113 | VAUXHALL |

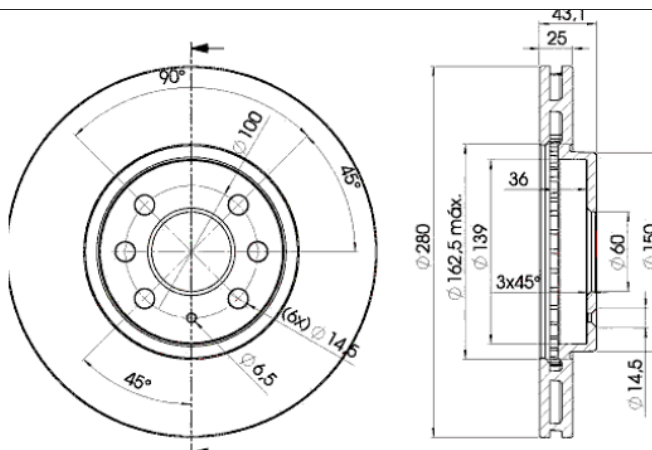

## 78BD9007-2

**E1 90R-02C0452/0118**



Ø280x25x43

| MAKE     |
|----------|
| OPEL     |
| VAUXHALL |



| Trac. | CC | Kw | CV |  |              |
|-------|----|----|----|--|--------------|
|       |    |    |    |  | Front / Rear |

### OPEL

|                                  |  |                  |     |      |    |     | <b>Estate Van (Compact car-C Segment)</b> |  |   |  |
|----------------------------------|--|------------------|-----|------|----|-----|---|--|---|--|
| <b>ASTRA H (L70) 02.04-10.14</b> |  |                  |     |      |    |     |   |  |   |  |
| 1.4 EcoTec (L70) (Z 14 XEP)      |  | Gasolina         | FWD | 1364 | 66 | 90  | 12.04-12.12                               |  | ■ |  |
| 1.6 EcoTec (L70) (Z 16 XEP)      |  | Gasolina         | FWD | 1598 | 76 | 103 | 02.04-11.04                               |  | ■ |  |
| 1.6 EcoTec (L70) (Z 16 XER)      |  | Gasolina         | FWD | 1598 | 85 | 116 | 10.06-12.10                               |  | ■ |  |
| 1.7 CDTI (L70) (Z 17 DTL)        |  | Diesel           | FWD | 1686 | 59 | 80  | 12.04-07.07                               |  | ■ |  |
| 1.9 CDTI (L70) (Z 19 DTL)        |  | Diesel           | FWD | 1910 | 74 | 101 | 08.05-12.12                               |  | ■ |  |
| <b>ASTRA H (A04) 08.04-10.10</b> |  |                  |     |      |    |     | <b>Estate (Compact car-C Segment)</b>     |  |   |  |
| 1.4 (L35) (Z 14 XEL)             |  | Gasolina         | FWD | 1364 | 55 | 75  | 08.04-10.10                               |  | ■ |  |
| 1.4 (L35) (Z 14 XEP)             |  | Gasolina         | FWD | 1364 | 66 | 90  | 08.04-10.10                               |  | ■ |  |
| 1.6 CNG                          |  | Gasolina         | FWD | 1598 | 69 | 94  | 11.05-                                    |  | ■ |  |
| 1.6 (L35) (Z 16 XE1)             |  | Gasolina         | FWD | 1598 | 77 | 105 | 08.04-10.10                               |  | ■ |  |
| 1.6 (L35) (Z 16 XEP)             |  | Gasolina         | FWD | 1598 | 77 | 105 | 08.04-10.10                               |  | ■ |  |
| 1.4 LPG (L35) (Z 14 XEP)         |  | Gasol./Gas (LPG) | FWD | 1364 | 66 | 90  | 08.09-10.10                               |  | ■ |  |
| 1.6 LPG (L35) (Z 16 XER)         |  | Gasol./Gas (LPG) | FWD | 1598 | 85 | 116 | 08.09-10.10                               |  | ■ |  |
| <b>ASTRA H (A04) 01.04-01.11</b> |  |                  |     |      |    |     | <b>Hatchback (Compact car-C Segment)</b>  |  |   |  |
| 1.2                              |  | Gasolina         | FWD | 1199 | 48 | 65  | 10.06-                                    |  | ■ |  |
| 1.2 (L48) (Z 12 XEP)             |  | Gasolina         | FWD | 1229 | 59 | 80  | 08.05-10.10                               |  | ■ |  |
| 1.4 (L48) (Z 14 XEL)             |  | Gasolina         | FWD | 1364 | 55 | 75  | 04.04-10.04                               |  | ■ |  |
| 1.4                              |  | Gasolina         | FWD | 1364 | 59 | 80  | 04.04-10.04                               |  | ■ |  |
| 1.4 (L48) (Z 14 XEP)             |  | Gasolina         | FWD | 1364 | 66 | 90  | 03.04-10.10                               |  | ■ |  |
| 1.6 CNG                          |  | Gasolina         | FWD | 1598 | 69 | 94  | 11.05-                                    |  | ■ |  |
| 1.6 (L48) (Z 16 XE1)             |  | Gasolina         | FWD | 1598 | 77 | 105 | 03.04-10.10                               |  | ■ |  |

# LISTA DE APLICACIONES - BUYERS GUIDE

|  |  |                  |     |      |  |     |             |   |  |
|--|--|------------------|-----|------|--|-----|-------------|---|--|
| 1.6 (L48) (Z 16 XEP)                     |  | Gasolina         | FWD | 1598 | 77   | 105 | 03.04-10.10 | ■ |  |
| 1.6 (L48) (A 16 XER)                     |  | Gasolina         | FWD | 1598 | 85   | 116 | 11.06-09.09 | ■ |  |
| 1.6 (L48) (Z 16 XER)                     |  | Gasolina         | FWD | 1598 | 85   | 116 | 11.06-09.09 | ■ |  |
| 1.4 LPG (L48) (Z 14 XEP)                 |  | Gasol./Gas (LPG) | FWD | 1364 | 66   | 90  | 08.09-10.10 | ■ |  |
| <b>ASTRA H (A04) 02.07-12.13</b>         |  |                  |     |      | <b>Saloon (Compact car-C Segment)</b>      |     |             |   |  |
| 1.4 (L69) (Z 14 XEP)                     |  | Gasolina         | FWD | 1364 | 66   | 90  | 02.07-06.10 | ■ |  |
| 1.6 (L69) (Z 16 XEP)                     |  | Gasolina         | FWD | 1598 | 77   | 105 | 02.07-06.10 | ■ |  |
| 1.8 (L69) (A 18 XER)                     |  | Gasolina         | FWD | 1796 | 103  | 140 | 02.07-06.10 | ■ |  |
| 1.8 (L69) (Z 18 XER)                     |  | Gasolina         | FWD | 1796 | 103  | 140 | 02.07-06.10 | ■ |  |
| 1.3 CDTi (L69) (Z 13 DTH)                |  | Diesel           | FWD | 1248 | 66   | 90  | 02.07-10.10 | ■ |  |
| 1.7 CDTi (L69) (Z 17 DTJ)                |  | Diesel           | FWD | 1686 | 81   | 110 | 02.07-06.10 | ■ |  |
| <b>ASTRA H CLASSIC (A04) 01.09-05.14</b> |  |                  |     |      | <b>Estate (Compact car-C Segment)</b>      |     |             |   |  |
| 1.4 (L35) (Z 14 XEP)                     |  | Gasolina         | FWD | 1364 | 66   | 90  | 01.09-05.14 | ■ |  |
| 1.8 (L35) (Z 18 XER)                     |  | Gasolina         | FWD | 1796 | 103  | 140 | 01.12-05.14 | ■ |  |
| 1.7 CDTi (L35) (Z 17 DTJ)                |  | Diesel           | FWD | 1686 | 81   | 110 | 01.09-05.14 | ■ |  |
| <b>ASTRA H CLASSIC (A04) 01.09-</b>      |  |                  |     |      | <b>Hatchback (Compact car-C Segment)</b>   |     |             |   |  |
| 1.4 (L48) (Z 14 XEP)                     |  | Gasolina         | FWD | 1364 | 66   | 90  | 01.09-05.14 | ■ |  |
| 1.6 (L48) (Z 16 XER)                     |  | Gasolina         | FWD | 1598 | 85   | 116 | 01.09-05.14 | ■ |  |
| 1.7 CDTi (L48) (A 17 DTJ)                |  | Diesel           | FWD | 1686 | 81   | 110 | 01.09-05.14 | ■ |  |
| 1.7 CDTi (L48) (Z 17 DTJ)                |  | Diesel           | FWD | 1686 | 81   | 110 | 01.09-05.14 | ■ |  |
| <b>ASTRA H CLASSIC (A04) 01.09-05.14</b> |  |                  |     |      | <b>Saloon (Compact car-C Segment)</b>      |     |             |   |  |
| 1.8 (L69) (Z 18 XER)                     |  | Gasolina         | FWD | 1796 | 103  | 140 | 01.09-09.12 | ■ |  |
| 1.7 CDTi (L69) (Z 17 DTJ)                |  | Diesel           | FWD | 1686 | 81   | 110 | 01.09-05.14 | ■ |  |
| 1.7 CDTi (L69) (A 17 DTR)                |  | Diesel           | FWD | 1686 | 92   | 125 | 01.09-05.14 | ■ |  |
| 1.7 CDTi (L69) (Z 17 DTR)                |  | Diesel           | FWD | 1686 | 92   | 125 | 01.09-05.14 | ■ |  |
| <b>ASTRA H GTC (A04) 03.05-10.10</b>     |  |                  |     |      | <b>Hatchback (Compact car-C Segment)</b>   |     |             |   |  |
| 1.2                                      |  | Gasolina         | FWD | 1199 | 48   | 65  | 10.06-      | ■ |  |
| 1.2 (L08)                                |  | Gasolina         | FWD | 1229 | 59   | 80  | 08.05-10.10 | ■ |  |
| 1.4 (L08) (Z 14 XEP)                     |  | Gasolina         | FWD | 1364 | 66   | 90  | 03.05-10.10 | ■ |  |
| 1.6 CNG                                  |  | Gasolina         | FWD | 1598 | 69   | 94  | 11.05-      | ■ |  |
| 1.6 (L08) (Z 16 XE1)                     |  | Gasolina         | FWD | 1598 | 77   | 105 | 03.05-10.10 | ■ |  |
| 1.6 (L08) (Z 16 XEP)                     |  | Gasolina         | FWD | 1598 | 77   | 105 | 03.05-10.10 | ■ |  |
| 1.6 (L08) (Z 16 XER)                     |  | Gasolina         | FWD | 1598 | 85   | 116 | 12.06-10.10 | ■ |  |
| 1.6 Turbo (L08) (A 16 LET)               |  | Gasolina         | FWD | 1598 | 132  | 180 | 02.07-10.10 | ■ |  |
| 1.6 Turbo (L08) (Z 16 LET)               |  | Gasolina         | FWD | 1598 | 132  | 180 | 02.07-10.10 | ■ |  |
| 1.7 CDTi (L08) (Z 17 DTL)                |  | Diesel           | FWD | 1686 | 59   | 80  | 03.05-10.10 | ■ |  |
| <b>ASTRA H TwinTop (A04) 09.05-12.13</b> |  |                  |     |      | <b>Convertible (Compact car-C Segment)</b> |     |             |   |  |
| 1.4 (L67) (Z 14 XEP)                     |  | Gasolina         | FWD | 1364 | 66   | 90  | 10.05-10.10 | ■ |  |
| 1.6 (L67) (Z 16 XE1)                     |  | Gasolina         | FWD | 1598 | 77   | 105 | 09.05-10.10 | ■ |  |
| 1.6 (L67) (Z 16 XEP)                     |  | Gasolina         | FWD | 1598 | 77   | 105 | 09.05-10.10 | ■ |  |
| 1.6 (L67) (Z 16 XER)                     |  | Gasolina         | FWD | 1598 | 85   | 116 | 12.06-10.10 | ■ |  |
| <b>VAUXHALL</b>                          |  |                  |     |      |  |     |             |   |  |
| <b>ASTRA Mk V (H) (A04) 08.04-10.12</b>  |  |                  |     |      | <b>Estate (Compact car-C Segment)</b>      |     |             |   |  |
| 1.4 (L35) (Z 14 XEP)                     |  | Gasolina         | FWD | 1364 | 66   | 90  | 08.04-03.09 | ■ |  |
| 1.6 (L35) (Z 16 XE1)                     |  | Gasolina         | FWD | 1598 | 77   | 105 | 08.04-03.09 | ■ |  |
| 1.6 (L35) (Z 16 XEP)                     |  | Gasolina         | FWD | 1598 | 77   | 105 | 08.04-03.09 | ■ |  |
| 1.6 (L35) (Z 16 XER)                     |  | Gasolina         | FWD | 1598 | 85   | 115 | 08.04-03.11 | ■ |  |
| 1.9 CDTi 16V (L35) (Z 19 DTJ)            |  | Diesel           | FWD | 1910 | 88   | 120 | 08.04-03.09 | ■ |  |

# LISTA DE APLICACIONES - BUYERS GUIDE

|   |  |          |     |      | <b>Hatchback (Compact car-C Segment)</b>  |     |             |   |  |
|---|--|----------|-----|------|---|-----|-------------|---|--|
| <b>ASTRA Mk V (H) (A04) 01.04-03.11</b>             |  |          |     |      |   |     |             |   |  |
| 1.4 (L48) (Z 14 XEP)                                |  | Gasolina | FWD | 1364 | 66  | 90  | 01.04-05.09 | ■ |  |
| 1.6 (L48) (Z 16 XE1)                                |  | Gasolina | FWD | 1598 | 77  | 105 | 01.04-05.09 | ■ |  |
| 1.6 (L48) (Z 16 XEP)                                |  | Gasolina | FWD | 1598 | 77  | 105 | 01.04-05.09 | ■ |  |
| 1.6 (L48) (A 16 XER)                                |  | Gasolina | FWD | 1598 | 85  | 115 | 01.04-05.09 | ■ |  |
| 1.6 (L48) (Z 16 XER)                                |  | Gasolina | FWD | 1598 | 85  | 115 | 01.04-05.09 | ■ |  |
| 1.6 Turbo (L48) (A 16 LET)                          |  | Gasolina | FWD | 1598 | 132                                       | 180 | 09.06-09.09 | ■ |  |
| 1.6 Turbo (L48) (Z 16 LET)                          |  | Gasolina | FWD | 1598 | 132                                       | 180 | 09.06-09.09 | ■ |  |
| <b>ASTRA Mk V (H) Sport Hatch (A04) 02.05-11.10</b> |  |          |     |      | <b>Hatchback (Compact car-C Segment)</b>  |     |             |   |  |
| 1.4 i 16V (L08) (Z 14 XEP)                          |  | Gasolina | FWD | 1364 | 66  | 90  | 03.05-11.10 | ■ |  |
| 1.6 (L08) (Z 16 XEP)                                |  | Gasolina | FWD | 1598 | 77  | 105 | 02.05-11.10 | ■ |  |
| 1.6 i 16V (L08) (A 16 XER)                          |  | Gasolina | FWD | 1598 | 85  | 116 | 12.06-11.10 | ■ |  |
| 1.6 i 16V (L08) (Z 16 XER)                          |  | Gasolina | FWD | 1598 | 85  | 116 | 12.06-11.10 | ■ |  |
| 1.6 (L08) (A 16 LET)                                |  | Gasolina | FWD | 1598 | 132                                       | 179 | 10.06-11.10 | ■ |  |
| 1.6 (L08) (Z 16 LET)                                |  | Gasolina | FWD | 1598 | 132                                       | 179 | 10.06-11.10 | ■ |  |
| 1.7 CDTi (L08) (A 17 DTJ)                           |  | Diesel   | FWD | 1686 | 81  | 110 | 02.07-11.09 | ■ |  |
| 1.7 CDTi (L08) (Z 17 DTJ)                           |  | Diesel   | FWD | 1686 | 81  | 110 | 02.07-11.09 | ■ |  |
| <b>ASTRAVAN Mk V (H) (A04) 03.05-</b>               |  |          |     |      | <b>Estate Van (Compact car-C Segment)</b> |     |             |   |  |
| 1.4 i (Z 14 XEP)                                    |  | Gasolina | FWD | 1364 | 66  | 90  | 03.05-      | ■ |  |
| 1.6 (Z 16 XE1)                                      |  | Gasolina | FWD | 1598 | 76  | 103 | 03.05-      | ■ |  |
| 1.6 (Z 16 XEP)                                      |  | Gasolina | FWD | 1598 | 76  | 103 | 03.05-      | ■ |  |
| 1.3 CDTi (Z 13 DTH)                                 |  | Diesel   | FWD | 1248 | 66  | 90  | 08.05-      | ■ |  |
| 1.7 CDTi (A 17 DTJ)                                 |  | Diesel   | FWD | 1686 | 81  | 110 | 06.11-12.13 | ■ |  |
| 1.7 CDTi (Z 17 DTJ)                                 |  | Diesel   | FWD | 1686 | 81  | 110 | 06.11-12.13 | ■ |  |
| <b>COMBO Mk II (C) (F25) 09.01-02.12</b>            |  |          |     |      | <b>Box Body/MPV (LCVs-N1 Segment)</b>     |     |             |   |  |
| 1.4 i 16V (Z 14 XEP)                                |  | Gasolina | FWD | 1364 | 66  | 90  | 01.04-11.11 | ■ |  |
| <b>CORSAVAN Mk II (C) (X01) 09.00-11.06</b>         |  |          |     |      | <b>Hatchback Van (LCVs-N1 Segment)</b>    |     |             |   |  |
| 1.7 DI 16V (F08) (Y 17 DTL)                         |  | Diesel   | FWD | 1686 | 48  | 65  | 09.00-06.06 | ■ |  |
| 1.7 DTI 16V (F08) (Y 17 DT)                         |  | Diesel   | FWD | 1686 | 55  | 75  | 09.00-06.06 | ■ |  |